



A EVOLUÇÃO TRANSFORMA

CATÁLOGO DE PRODUTOS 2021



PROGÁS

equipamentos gastronômicos



BRAESI

equipamentos gastronômicos



Há décadas, a Progás e a Braesi oferecem ao mercado inúmeros equipamentos gastronômicos para impulsionar o seu negócio. Presentes em todo o Brasil e no exterior, carregam a palavra EVOLUÇÃO no cerne do negócio; e investem todos os dias em processos, tecnologias e pessoas que possam transformar a experiência de quem cozinha.

Sob o slogan "Evolução para quem cozinha", a Progás e a Braesi esperam seguir crescendo junto com todo o setor de alimentação, como restaurantes, bares, cafés, padarias, açougues, supermercados, empreendimentos individuais e empresas de eventos.

A gama de produtos oferecidos pelas empresas é produzida com o apoio de cerca de 400 funcionários em um complexo industrial de 20.000 m² de área construída em Caxias do Sul – RS. Nele, a Progás e a Braesi realizam desde a manufatura de chapas metálicas até complexos sistemas de fabricação, apoiados pelo maquinário de alta tecnologia que otimiza a sua produção.







Aponte seu leitor de QR Code e **assista ao vídeo institucional das empresas.**



Confira neste catálogo os fogões, fornos turbos, assadores rotativos, buffets, amassadeiras, modeladoras, cilindros, batedeiras planetárias, chapas bifeteiras, fritadores, cortadores de legumes, fatiadores, entre outros equipamentos gastronômicos que transformam o dia a dia de quem cozinha.



 /Progás
 @progas_braesi
 /ProgásOficial | BraesiOficial
 www.progas.com.br | www.braesi.com.br

ÍNDICE DE PRODUTOS POR CÓDIGO

PROGÁS			
CÓDIGO	PÁG.		
BMI P/ PMD	39	PGC-005	54
BMI P/ PMDI	52	PM-200	46
BMSI P/ PMS	42,45 e 50	PM-400 F	46
CABEÇOTE PARA TRANSIÇÃO GÁS - ELÉTRICO	25	PMD-100	38
CAVALETE MINI CHEF	71	PMD-200 F LINHA	38
CESTO DUPLO	28	PMD-300 F	38
CESTO GRANDE	22	PMD-400 F	38
CESTO MÉDIO	22	PMD-600 F	39
CESTO PEQUENO	22	PMD-MBM C/ BMI	39
CESTO RETANGULAR PEQ.	20	PMD-MBM S/ BMI	39
CESTO SIMPLES	28	PMD-MCH	39
CHAPA CAMPEIRA	54	PMDI-200 LINHA	51
CHAPA COM ALÇAS	54	PMDI-400 F	51
CHAPA SEM SUPORTE	39, 42, 45, 50 e 52	PMDI-400 F ENCOSTO	51
CUBA INOX GN 1/1 100 MM PRB	59	PMDI-600 F	51
CUBA INOX GN 1/2 65 MM PRBF	59	PMDI-600 F ENCOSTO	51
CUBA INOX GN 1/2 100 MM PRB	59	PMDI-MBM C/ BMI	52
ESPETO GARFO	67	PMDI-MBM S/ BMI	52
ESPETO GRELHA MÚLTIPLO PARA CORAÇÃO	68	PMDI-MCH	52
ESPETO GRELHA MÚLTIPLO PARA PEIXES	68	PMI-400 F	49
ESPETO UNIVERSAL	67	PMI-402 F	49
ESPETO PARA PR-199 e PR-199E	67	PMI-600 F	50
ESTEIRA 5 TIRAS	78	PMI-603 F	49
ESTEIRA FLANDRES	78	PMI-MBM C/ BMI	50
ESTEIRA ONDULADA	78	PMI-MBM S/ BMI	50
ESTEIRA RETA	78	PMI-MCH	50
F1B3	54	PMS-100	40
F1B7	54	PMS-110	40
F1B7P	54	PMS-200	40
F2B6	54	PMS-300	40
F2B10	54	PMS-400 F	41
F2B10P	54	PMS-400 FCH	41
FGE-110 GOURMET	37	PMS-510 F	41
FSI-500 N	42, 45 e 46	PMS-510 FCH	41
FSI-680 N	39, 42 e 45	PMS-600 F	41
FSI-680 NI	50 e 52	PMS-600 FCH	41
FSIA-500 N	48	PMS-MBM C/ BMSI	42 e 45
FSP-6800 AT	39, 42 e 45	PMS-MBM S/ BMSI	42 e 45
FSP-6800 AT COM PEDESTAL	72	PMS-MCH	42 e 45
GIRAMOG-07 / 05	33	PMSD-101	43
GÔNDOLAS	82	PMSD-201 F	43
KIT PRENSA PÃO	9	PMSD-202	43
MES-004	63	PMSD-301 F	43
PCA-200 N STYLE	78	PMSD-402 F	44
PCE-200	78	PMSD-402 FCH	44
PEDESTAL PARA CHAPAS	9	PMSD-512 F	44
PEL-101 G2	57	PMSD-603 F	44
PEL-151 G2	57	PMSD-603 FCH	44
PFI-100	53	PR-02 G STYLE	13
PFI-200	53	PR-03 G STYLE	13
PGC-004	54	PR-10 E GN	19
		PR-10 G GN	19
		PR-14 E	23
		PR-14 E MESA	20
		PR-14 G	23
		PR-14 G MESA G2	20
		PR-20 E GN	19
		PR-20 G GN	19
		PR-30 G G2	20
		PR-70 E	21
		PR-70 EL	22
		PR-70 G G2	21
		PR-90 E	26
		PR-100 E STYLE	26
		PR-111	58
		PR-199	67
		PR-199 E	67
		PR-200 E	26
		PR-220 G STYLE	7
		PR-220 E STYLE	7
		PR-300 E STYLE	26
		PR-310 E	21
		PR-310 G G2	21
		PR-350 E STYLE	7
		PR-350 G STYLE	7
		PR-352 G STYLE	13
		PR-450 G STYLE	8
		PR-500 E	7
		PR-500 G STYLE	7
		PR-550 G STYLE	7
		PR-621	67
		PR-623	66
		PR-631	67
		PR-634	66
		PR-640 E	31
		PR-640 VI	31
		PR-650 G STYLE	7
		PR-700 E STYLE	10
		PR-700 G STYLE	10
		PR-750 G STYLE	8
		PR-800 E STYLE	8
		PR-800 G STYLE	8
		PR-880 G STYLE	10
		PR-950 E STYLE	11
		PR-950 G	10
		PR-952 G	11
		PR-1000 E STYLE	8
		PR-1000 G STYLE	8
		PR-1100 G STYLE	11
		PR-1200 G STYLE	9
		PR-1200 P STYLE	9
		PR-1600 G	9
		PR-1600 P	9
		PR-2000 BPAT STYLE	24
		PR-2000 BPG STYLE	24
		PR-2000 E STYLE	27
		PR-2000 EL	27
		PR-3000 BPAT STYLE	25
		PR-3000 BPG	25
		PR-3000 E STYLE	27
		PR-3000 EL	28
		PR-2008 E	24

PR-2008 EL	27	PRP-004 G2	63	AES-60/1 N STYLE	88
PR-3008 E	23	PRP-124 G	65	ALI-03	89
PR-3008 EL	28	PRP-242 G4	65	ALI-05	88
PR-6100 DUO	66	PRP-400 STYLE G2	71	ALI-15/1	89
PRA-45 E	07	PRP-482 G4	65	ALI-25/1 G3	89
PRB-06 GN	58 e 59	PRP-750 G2 S/KG	72	AR-15/1 G3	90
PRB-08 GN	58 e 59	PRP-770 G2 S/KG	72	AR-25/1 G3	90
PRB-10 GN	58	PRP-800 G2 S/KG	72	AR-25/1 T G3	90
PRBF-30 GN	58	PRP-860 G	72	AR-50 N STYLE	90
PRBF-40 GN	58	PRP-900 G2 S/KG	73	BCM-245	92
PRBF-50 GN	58	PRP-900 DP G2 S/KG	73	BCMF-300 F	109
PRC-01	68	PRP-1000 G2 S/KG	73	BCMV-300 V	109
PRCA-340	69	PRP-1500 AT G2	74	BDL-10	105
PRCL-200 G2	77	PRP-1500 G2 KG	73	BMES-1780 / 178	98
PRCL-400 G2	77	PRP-5000 NEW LIGHT	61	BLB-300	92
PRCB-210 STYLE	9	PRP-5000 NEW ELETIC	61	BMC-05 G2	97
PRCB-210 P STYLE	9	PRP-8000 E STYLE	62	BMC-10/1 G2	97
PRCB-800 STYLE	9	PRP-8000 STYLE G2	62	BMC-22/1 G2	97
PRD-200 G2	13	PRP-10000 E STYLE	62	BMP-150 I	101
PREA-100 M	47	PRP-10000 STYLE G2	62	BPEL-18/1 G2	91
PREA-200	47	PRP-12000 STYLE G2	62	BPEL-05 PREMIUM G2	91
PREA-200 FF	48	PRPE-400 STYLE G2	71	BPEL-12/1 G3	91
PREA-300	47	PRPE-200	71	BPQ-03	108
PREA-300 FF	48	PRPE-770 G2	74	BPTI-300	108
PREA-400 F	47	PRPE-900 G2	74	BPTL-300	108
PREA-400 F FF	48	PRPI-800 G2 KG	74	BRC-50 G2	106
PREST-004	81	PRPI-900 G2 KG	74	BSIM-178 PLUS SEMI-INOX	98
PREST-006	81	PRR-040 G	69	BSFM-1780/1	98
PRF-45 E	23	PRR-050 N STYLE	68	BSFP-2820/1	99
PRG-01	68	PRR-051 E G2 COLOR STYLE	68	BSFPI-282 SEMI-INOX	99
PRGE-200 GOURMET	37	PRR-051 G2 COLOR STYLE	68	CB-30 STYLE	93
PRGE-402 F GOURMET	37	PRRC-05	68	CB-38	92
PRK-06 E STYLE	15	PRRT-520 G2 COLOR STYLE	68	CBI-500/1 N STYLE	93
PRK-12 E STYLE	15	PRSB-10	15	CBPI-40/1 G2	93
PRK-60 G STYLE	15	PRT-07 ST GÁS	22	CFBA-30/1	99
PRK-120 G STYLE	15	PRTL-8000 STYLE	62	DES-10	103
PRKB-10	15	PRTL-8000 STYLE	62	DES-20	103
PRKF-101 ER	16	PRTL-10000 STYLE	62	DES-60/1 G2	103
PRKF-101 G	16	PRTL-10000 STYLE	62	DVB-30 N	94
PRKF-202 E	16	PRV-03 E	30	FB-12/1	95
PRKF-202 E/Q	16	PRV-04 E	30	FC-01	106
PRKF-202 E/R	16	PRV-05 E	31	FLB-180	105
PRKF-202 G	16	PRV-06 DE	31	KIT MOEDOR DE CARNE	88
PRKF-202 G/R	16	SALIVADOR	59	M-160 G2	95
PRMOG-05	33			M-180 G2	95
PRMOG-07	33			M-190 G2	95
PRMOG-07 E	34			MB-35/1 G2	94
PRMQ-10	34			MBMJ-22/1 STYLE G2	94
PRMQ-10 COOKTOP	34			MBR-10	95
PRMQ-15	35			MBR-015 G2	95
PRMQ-22	35			MBR-018 G2	95
PRMQ-40	35			MES-30	94
PRMQI-25	35			MES-100	106
PROGUITA	29			MP-02	95
PROGUITA COM PEDESTAL	29			RQ-01	106
PRP-004 PLUS	63				

BRAESI	
CÓDIGO	PÁG.
ADB-02 G2	101
AELI-310	89
AELI-520	88
AES-05	87
AES-15/1	87
AES-25/1 N STYLE	87
AES-40/1 N STYLE	88

ÍNDICE DE PRODUTOS PROGÁS

Grills, Chapas, Char Broiler e Sanduicheiras	06
Derretedeira e Molheiras	12
Máquinas de Bubble Waffle e Crepe	14
Fritadores e Tachos	18
Cortadores de Legumes	29
Estufas	30
Misturadores	32
Fogões	36
Aquecedores de Louças e Buffets	56
Fornos Turbos	60
Fornos Assadores	64
Fornos Refratários	70
Câmaras de Crescimento	76
Estantes e Gôndolas	80



PROGÁS

equipamentos gastronômicos





GRILLS, CHAPAS, CHAR BROILER E SANDUICHEIRAS





Saiba mais sobre o Grill Elétrico PRA-45 E. Aponte seu leitor de QR Code e assista ao vídeo.



GRILL ELÉTRICO PRA-45 E

- Coletor de gordura que facilita a higienização;
- Abertura regulável da prensa pão;
- Chapa em Alumínio Fundido.

medidas totais (AxLxP)	peso líq.	consumo médio	potência
366 x 440 x 599 mm	20 kg	1,8 kWh	2500 W - 220 V 2200 W - 127 V



PR-500 G STYLE

**GRILL PR-500 G STYLE
GRILL PR-550 G STYLE**

- Queimadores com gaveta móvel;
- O modelo PR-550 G Style é utilizado exclusivamente como prensa para pão.

modelo	medidas totais (AxLxP)	peso líq.	consumo médio
PR-500 G Style	173 x 490 x 430 mm	8,8 kg	0,19 kg/h
PR-550 G Style	176 x 521 x 514 mm	12,8 kg	0,32 kg/h



PR-220 E STYLE



**GRILL PR-220 E STYLE
GRILL PR-350 E STYLE**

- Aquecimento através de resistência elétrica inferior e superior controladas por termostato.

modelo	medidas totais (AxLxP)	peso líq.	consumo médio
PR-220 E Style	171 x 310 x 315 mm	4,5 kg	1,4 kWh
PR-350 E Style	168 x 324 x 429 mm	9,7 kg	



GRILL PR-500 E

- Aquecimento através de resistências elétricas inferior e superior controladas por termostato.

medidas totais (AxLxP)	peso líq.	consumo médio
168 x 484 x 430 mm	13 kg	1,7 kWh



PR-220 G STYLE

**GRILL PR-220 G STYLE
GRILL PR-350 G STYLE**

- Queimadores com gaveta móvel.

modelo	medidas totais (AxLxP)	peso líq.	consumo médio
PR-220 G Style	170 x 340 x 315 mm	4,5 kg	0,10 kg/h
PR-350 G Style	173 x 348 x 430 mm	8,5 kg	0,15 kg/h



CHAPA BIFETEIRA PR-650 G STYLE

- Chapa reforçada e inteira para fritura;
- Queimadores com gaveta móvel.

medidas totais (AxLxP)	peso líq.	consumo médio
242 x 622 x 464 mm	18 kg	0,35 kg/h





CHAPA BIFETEIRA PR-450 G STYLE

- Chapa para fritura reforçada e inteiriça;
- Queimadores com gaveta móvel.

medidas totais (AxLxP)	peso líq.	consumo médio
134 x 490 x 356 mm	6 kg	0,19 kg/h



CHAPA BIFETEIRA PR-800 G STYLE

- Chapa reforçada e inteiriça para fritura;
- Queimadores com gaveta móvel.

modelo	medidas totais (AxLxP)	peso líq.	consumo médio
PR-800 G Style	243 x 830 x 525 mm	31 kg	0,48 kg/h
PR-800 P Style (modelo com pedestal)	1022 x 830 x 525 mm	40,7 kg	



CHAPA BIFETEIRA PR-1000 G STYLE

- Chapa reforçada e inteiriça para fritura;
- Queimadores com gaveta móvel.

modelo	medidas totais (AxLxP)	peso líq.	consumo médio
PR-1000 G Style	243 x 1025 x 528 mm	37,5 kg	0,72 kg/h
PR-1000 P Style (modelo com pedestal)	1022 x 1025 x 528 mm	48 kg	



CHAPA BIFETEIRA PR-750 G STYLE

- Chapa reforçada e inteiriça para fritura;
- Queimadores com gaveta móvel.

medidas totais (AxLxP)	peso líq.	consumo médio
147 x 727 x 367 mm	13 kg	0,4 kg/h



CHAPA BIFETEIRA ELÉTRICA PR-800 E STYLE

- Chapa reforçada e inteiriça para fritura;
- Duas zonas de aquecimento e controle de temperatura individual.

medidas totais (AxLxP)	peso líq.	consumo médio	chapa
243 x 800 x 508 mm	34,8 kg	2,8 kWh	785 x 485 mm



CHAPA BIFETEIRA ELÉTRICA PR-1000 E STYLE

- Chapa reforçada e inteiriça para fritura;
- Duas zonas de aquecimento e controle de temperatura individual.

medidas totais (AxLxP)	peso líq.	consumo médio	chapa
243 x 1001 x 517 mm	43,5 kg	3,5 kWh	985 x 485 mm





CHAPA BIFETEIRA PR-1200 G STYLE

- Chapa reforçada e inteira para fritura;
- Queimadores com gaveta móvel.

modelo	medidas totais (AxLxP)	peso líq.	consumo médio
PR-1200 G Style	243 x 1227 x 528 mm	49 kg	0,98 kg/h
PR-1200 P Style (modelo com pedestal)	1022 x 1227 x 528 mm	60,5 kg	



Grelhas removíveis, antiaderentes e autolimpantes



CHAPA BIFETEIRA PR-1600 G

- Chapa reforçada e inteira para fritura;
- Queimadores com gaveta móvel.

modelo	medidas totais (AxLxP)	peso líq.	consumo médio
PR-1600 G	311 x 1627 x 663 mm	105 kg	1,5 kg/h
PR-1600 P (modelo com pedestal)	1177 x 1627 x 663 mm	125,4 kg	



Grelhas removíveis, antiaderentes e autolimpantes



CHAR BROILER PRCB-210 STYLE

- Chapa mista reforçada para frituras e grelhados;
- Queimadores com gaveta móvel.

modelo	medidas totais (AxLxP)	peso líq.	consumo médio
PRCB-210 Style	243 x 1027 x 542 mm	36,3 kg	1,2 kg/h
PRCB-210 P Style (com pedestal opcional)	1022 x 1027 x 542 mm	46,8 kg	



CHAR BROILER PRCB-800 STYLE

- Grelha reforçada e inteira para fritura;
- Queimadores com gaveta móvel.

medidas totais (AxLxP)	peso líq.	consumo médio
234 x 833 x 558 mm	24,5 kg	0,96 kg/h



ACESSÓRIOS OPCIONAIS:



PEDESTAL PARA CHAPAS

Disponível para:
PR-800 G Style, PR-1000 G Style, PR-1200 G Style,
PR-1600 G, PRCB-210 Style,
PR-800 E e PR-1000 E.



KIT PRENSA PÃO

Área útil da chapa (LxP): 370 x 470 mm

Disponível para:
PR-800 G Style, PR-1000 G Style, PR-1200 G Style,
PR-800 E e PR-1000 E.

**SANDUICHEIRA PR-700 E STYLE**

- Aquecimento através de resistências elétricas inferior e superior controladas por termostatos.

medidas totais (AxLxP)	peso líq.	consumo médio
168 x 648 x 430 mm	11,2 kg	2,0 kWh

**SANDUICHEIRA PR-880 G STYLE**

- Queimadores com gaveta móvel.

medidas totais (AxLxP)	peso líq.	consumo médio
171 x 814 x 430 mm	11,8 kg	0,34 kg/h

**SANDUICHEIRA PR-950 G**

- Queimadores com gaveta móvel.



medidas totais (AxLxP)	peso líq.	consumo médio
173 x 968 x 430 mm	13,8 kg	0,40 kg/h

**SANDUICHEIRA PR-700 G STYLE**

- Queimadores com gaveta móvel.

medidas totais (AxLxP)	peso líq.	consumo médio
172 x 658 x 430 mm	9,1 kg	0,3 kg/h





SANDUICHEIRA PR-950 E STYLE

- Aquecimento através de resistências elétricas inferior e superior controladas por termostatos.



medidas totais (AxLxP)	peso líq.	consumo médio
168 x 968 x 430 mm	19,3 kg	2,5 kWh



SANDUICHEIRA PR-952 G

- Queimadores com gaveta móvel.



medidas totais (AxLxP)	peso líq.	consumo médio
176 x 968 x 430 mm	16,5 kg	0,38 kg/h



SANDUICHEIRA PR-1100 G STYLE

- Queimadores com gaveta móvel.



medidas totais (AxLxP)	peso líq.	consumo médio
173 x 1135 x 430 mm	17,5 kg	0,49 kg/h



DERRETEDEIRA E MOLHEIRAS

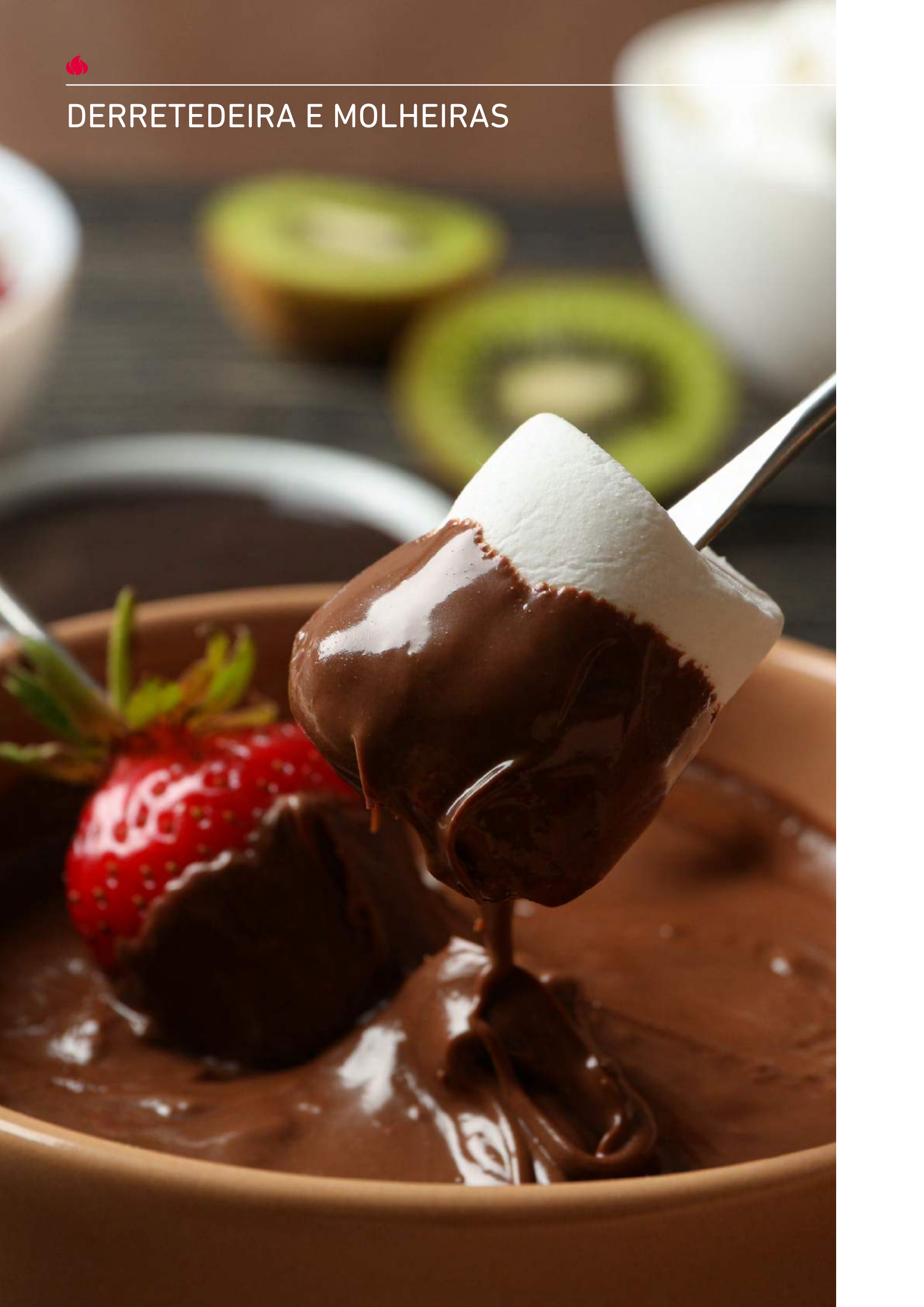



IDEAL PARA DERRETER:
Chocolate, queijo e similares em banho-maria.

Estrutura, cubas e tampa em aço inox



Capacidade por cuba:
2,5 kg

Controle automático de temperatura por termostato



DERRETEDEIRA DE CHOCOLATE PRD-200 G2

ELÉTRICA
127 OU 220V

COM 2 CUBAS

RESISTÊNCIA
950 W

medidas totais (AxLxP)	peso líq.	consumo médio
183 x 272 x 438 mm	3,4 kg	0,6 kWh

Prensa pão



Cubas de aço inox:
50 x 160 x 260 mm

Tampas em vidro

MOLHEIRA PR-352 G STYLE

ACO INOX ESCOVADO

A GÁS BANHA PRESSAO

COM 2 CUBAS

COM PRENSA PAO

medidas totais (AxLxP)	peso líq.	consumo médio
209 x 734 x 429 mm	10 kg	0,3 kg/h

Tampas em vidro



Cubas de aço inox:
50 x 160 x 260 mm

Tampas em vidro



Cubas de aço inox:
50 x 160 x 260 mm

MOLHEIRA PR-02 G STYLE

medidas totais (AxLxP)	peso líq.	consumo médio
163 x 406 x 350 mm	4,8 kg	0,1 kg/h

ACO INOX ESCOVADO

A GÁS BANHA PRESSAO

COM 2 CUBAS

MOLHEIRA PR-03 G STYLE

medidas totais (AxLxP)	peso líq.	consumo médio
163 x 594 x 353 mm	6,2 kg	0,2 kg/h

ACO INOX ESCOVADO

A GÁS BANHA PRESSAO

COM 3 CUBAS



MÁQUINAS DE BUBBLE WAFFLE E CREPE





Saiba mais sobre a Bubble Waffle. Aponte seu leitor de QR Code e assista ao vídeo.



MÁQUINA DE BUBBLE WAFFLE PRKB-10



- Chapa antiaderente redonda, com 200 mm de diâmetro.

medidas totais (AxLxP)	peso líq.	consumo médio
272 x 222 x 586 mm	5,7 kg	1,0 kWh



ACESSÓRIO OPCIONAL:



PRSB-10 SUPORTE BUBBLE

Dimensões: ø 92 x altura de 165
Material: Aço carbono cromado.
Peso: 0,18 kg



MÁQUINA DE CREPE SUÍÇO PRK-06 E STYLE

- Com termostato para controle de temperatura;
- Versão elétrica.

medidas totais (AxLxP)	peso líq.	consumo médio
171 x 230 x 501 mm	8 kg	1,1 kWh



MÁQUINA DE CREPE SUÍÇO PRK-12 E STYLE

- Com termostato para controle de temperatura;
- Versão elétrica.

medidas totais (AxLxP)	peso líq.	consumo médio
194 x 275 x 409 mm	9 kg	1,4 kWh



MÁQUINA DE CREPE SUÍÇO PRK-60 G STYLE

- Versão a gás e baixa pressão.

medidas totais (AxLxP)	peso líq.	consumo médio
252 x 254 x 487 mm	8,5 kg	0,18 kg/h



MÁQUINA DE CREPE SUÍÇO PRK-120 G STYLE

- Versão a gás e baixa pressão.

medidas totais (AxLxP)	peso líq.	consumo médio
259 x 300 x 428 mm	10 kg	0,37 kg/h





Chapa com acabamento esmaltado

ø 330 mm

**MÁQUINA DE CREPE FRANCÊS PRKF-101 G**

- Queimadores de 100 mm em ferro fundido;
- Registro com estágio contínuo.

medidas totais (A x L x P)	peso líq.	consumo médio
139 x 401 x 448 mm	7,2 kg	0,18 kg/h



Chapa com acabamento esmaltado

Chapa redonda: ø 330 mm

**MÁQUINA DE CREPE FRANCÊS PRKF-101 ER**

- Manuseio e limpeza facilitados.

medidas totais (A x L x P)	peso líq.	consumo médio
148 x 328 x 346 mm	7,2 kg	0,8 kWh



Chapa quadrada: 330 x 330 mm

Chapa redonda: ø 330 mm



Chapas com acabamento esmaltado

MÁQUINA DE CREPE FRANCÊS PRKF-202 E

- Pode ser usada com chapas redondas, quadradas ou intercaladas;
- Resistência blindada de 1200 W;
- Com termostato para controle de temperatura individual.

modelo	medidas totais (A x L x P)	peso líq.	consumo médio
PRKF-202 E	141 x 811 x 470 mm	19,7 kg	1,7 kWh
PRKF-202 E/Q			
PRKF-202 E/R			

Q - com duas chapas quadradas | R - com duas chapas redondas



Chapa redonda: ø 330 mm

Chapa quadrada: 330 x 330 mm



Chapas com acabamento esmaltado

MÁQUINA DE CREPE FRANCÊS PRKF-202 G

- Pode ser usada com chapas redondas, quadradas ou intercaladas;
- Queimadores de 100 mm em ferro fundido;
- Registros com estágios contínuos.

modelo	medidas totais (A x L x P)	peso líq.	consumo médio
PRKF-202 G	145 x 849 x 440 mm	17,2 kg	0,36 kg/h
PRKF-202 G/R			

Q - com duas chapas quadradas | R - com duas chapas redondas





A wooden cutting board is filled with a variety of fried foods. The top half of the board is covered with several golden-brown, crispy chicken wings. Below the wings, there are french fries and a large pile of onion rings. The entire scene is set against a dark, textured background. The text 'FRITADORES E TACHOS' is overlaid in the top left corner.

FRITADORES E TACHOS



FRITADOR A ÓLEO PR-10 G GN

- Utiliza cuba gastronômica (GN) 1/2 65 mm.

medidas totais (AxLxP)	capac. óleo		peso liq.	consumo médio
	mínima	máxima		
426 x 338 x 432 mm	3 l	4,8 l	3,7 kg	0,35 kg/h



FRITADOR A ÓLEO PR-20 G GN

- Utiliza cuba gastronômica (GN) 1/2 65 mm.

medidas totais (AxLxP)	capac. óleo		peso liq.	consumo médio
	mínima	máxima		
426 x 602 x 432 mm	2 x 3 l	2 x 4,8 l	6,2 kg	0,7 kg/h



FRITADOR A ÓLEO PR-10 E GN

- Com resistência em aço inox e termostato automático para controle de temperatura;
- Utiliza cuba gastronômica (GN) 1/2 65 mm.

medidas totais (AxLxP)	capac. óleo		peso liq.	consumo médio
	mínima	máxima		
532 x 298 x 569 mm	3 l	4,8 l	3,8 kg	2,3 kWh



FRITADOR A ÓLEO PR-20 E GN

- Com resistência em aço inox e termostato automático para controle de temperatura;
- Utiliza cuba gastronômica (GN) 1/2 65 mm.

medidas totais (AxLxP)	capac. óleo		peso liq.	consumo médio
	mínima	máxima		
532 x 561 x 569 mm	2 x 3 l	2 x 4,8 l	6,9 kg	2 x 2,3 kWh



**FRITADOR A ÓLEO PR-30 G G2**

medidas totais (AxLxP)	capac. óleo		peso líq.	consumo médio
	mínima	máxima		
339 x 536 x 458 mm	3 l	7 l	6,1 kg	0,7 kg/h

**ACESSÓRIO OPCIONAL:****CESTO RETANGULAR PEQUENO**

Dimensões PR-30 G G2 (AxLxP): 90 x 250 x 130 mm

Dimensões demais modelos (AxLxP): 93 x 254 x 186 mm

Capacidade: 0,25 kg

Acompanha os modelos: PR-10 G G2, PR-10 E G2, PR-20 G G2, PR-20 E G2 e PR-30 G G2.

**TACHO FRITADOR A ÓLEO PR-14 G MESA G2**

medidas totais (AxLxP)	capac. óleo		peso líq.	consumo médio
	mínima	máxima		
275 x 634 x 536 mm	6,5 l	8 l	5,7 kg	0,43 kg/h

**TACHO FRITADOR A ÓLEO PR-14 E MESA**

- Com resistência em aço inox e termostato automático para controle de temperatura.

medidas totais (AxLxP)	capac. óleo		peso líq.	consumo médio
	mínima	máxima		
197 x 634 x 578 mm	6,5 l	8 l	5,1 kg	2,5 kWh





TACHO FRITADOR A ÓLEO PR-70 G G2

medidas totais (A x L x P)	capac. óleo		peso líq.	consumo médio
	mínima	máxima		
296 x 601 x 485 mm	3 l	5 l	4 kg	0,43 kg/h



TACHO FRITADOR A ÓLEO PR-70 E

medidas totais (A x L x P)	capac. óleo		peso líq.	consumo médio
	mínima	máxima		
213 x 601 x 528 mm	3 l	5 l	3,2 kg	2,35 kWh



TACHO FRITADOR A ÓLEO PR-310 G G2

medidas totais (A x L x P)	capac. óleo		peso líq.	consumo médio
	mínima	máxima		
298 x 467 x 358 mm	1,5 l	2 l	2,4 kg	0,35 kg/h



TACHO FRITADOR A ÓLEO PR-310 E

medidas totais (A x L x P)	capac. óleo		peso líq.	consumo médio
	mínima	máxima		
204 x 462 x 399 mm	1,5 l	2 l	2,4 kg	1,4 kWh



**TACHO FRITADOR A ÓLEO PRT-07 ST GÁS**

medidas totais (AxLxP)	peso líq.	consumo médio	capac. óleo	
			mínima	máxima
300 x 440 x 690 mm	3,1 kg	0,43 kg/h	3 l	5 l



Com kit gás de alta pressão

**TACHO FRITADOR PR-70 EL**

• Controle digital de fácil programação e display em LED.

medidas totais (AxLxP)	capac. óleo		peso líq.	consumo médio
	mínima	máxima		
213 x 601 x 500 mm	3 l	5 l	3,4 kg	2,5 kWh

**ACESSÓRIOS OPCIONAIS:****CESTO PEQUENO**Dimensões (øxA): 270 x 96 mm
Capacidade: 0,5 kgAcompanha os modelos:
PR-310 G2 e PR-310 E.**CESTO MÉDIO**Dimensões (øxA): 360 x 90 mm
Capacidade: 0,8 kgAcompanha os modelos:
PRT-07 ST Gás, PR-70 G2, PR-70 E G2, PR-90 E.**CESTO GRANDE**Dimensões (øxA): 413 x 140 mm
Capacidade: 1 kgAcompanha os modelos:
PR-14 G e PR-14 E,
PR-14 G mesa G2 e PR-14 E mesa.



Com kit gás de alta pressão

TACHO FRITADOR A ÓLEO PR-14 G

medidas totais (A x L x P)	peso líq.	consumo médio	capac. óleo	
			mínima	máxima
721 x 505 x 635 mm	9,3 kg	0,43 kg/h	6,5 l	8 l



FRITADOR ÁGUA E ÓLEO PRF-45 E

- Ideal para fritar batatas, empanados, salgados, bolinhos, frutos do mar, etc;
- Chave para aumento de potência: 5500 W para 9000 W.

medidas totais (A x L x P)	peso líq.	consumo médio	capacidade
1122 x 399 x 768 mm	26,1 kg	6,3 kWh	2 kg



TACHO FRITADOR A ÓLEO PR-14 E

- Com resistência em aço inox e termostato automático para controle de temperatura.

medidas totais (A x L x P)	peso líq.	consumo médio	capac. óleo	
			mínima	máxima
743 x 634 x 577 mm	9,3 kg	2,5 kWh	6,5 l	8 l



FRITADOR ÁGUA E ÓLEO PR-3008 E

- Ideal para estabelecimentos que exijam rapidez na entrega dos pratos;
- Chave de aumento de potência: 5000 W para 8000 W;
- Dois rodízios dianteiros com trava e dois traseiros sem trava.

medidas totais (A x L x P)	peso líq.	consumo médio	capacidade
974 x 869 x 547 mm	22 kg	5,6 kWh	2,5 kg



**FRITADOR ÁGUA E ÓLEO PR-2008 E**

- Resistência dupla;
- Chave de aumento de potência: 5000 W para 8000 W;
- Dois rodízios dianteiros com trava e dois traseiros sem trava.

medidas totais (AxLxP)	peso líq.	consumo médio	capacidade
974 x 569 x 549 mm	16,7 kg	4,5 kWh	1,5 kg

**FRITADOR ÁGUA E ÓLEO BAIXA PRESSÃO PR-2000 BPG STYLE**

- Cuba interna em aço inox 304;
- Registro de esfera para o escoamento da água e do óleo;
- Dois rodízios dianteiros com trava e dois traseiros sem trava.

medidas totais (AxLxP)	capacidade			peso líq.	consumo médio
	óleo	água	sal		
869 x 493 x 495 mm	18 l	3,5 l	350 g	20,2 kg	0,7 kg/h



Controlador digital com acendimento automático para controle de temperatura

FRITADOR ÁGUA E ÓLEO BAIXA PRESSÃO PR-2000 BPAT STYLE

- Cuba interna em aço inox 304;
- Registro de esfera para o escoamento da água e do óleo, termômetro e leitura de chama;
- Dois rodízios dianteiros com trava e dois traseiros sem trava;
- Tensão: 127 ou 220 V.

medidas totais (AxLxP)	capacidade			peso líq.	consumo médio
	óleo	água	sal		
987 x 601 x 627 mm	18 l	3,5 l	350 g	24,6 kg	0,7 kg/h





Controlador digital com acendimento automático para controle de temperatura



FRITADOR ÁGUA E ÓLEO BAIXA PRESSÃO PR-3000 BPAT STYLE

- Cuba interna em aço inox 304;
- Registro de esfera para o escoamento da água e do óleo e leitura de chama;
- Dois rodízios dianteiros com trava e dois traseiros sem trava;
- Tensão: 127 ou 220 V.

medidas totais (AxLxP)	peso líq.	consumo médio	capacidade		
			óleo	água	sal
986 x 896 x 627 mm	35 kg	1 kg/h	30 l	6 l	500 g



ACESSÓRIO OPCIONAL:



CABEÇOTE PARA TRANSIÇÃO GÁS - ELÉTRICO

Disponível para:
PR-3000 BPAT,
PR-3000 BPG,
PR-2000 BPG e
PR-2000 BPAT
com tensão 220 V.

FRITADOR ÁGUA E ÓLEO BAIXA PRESSÃO PR-3000 BPG

- Cuba interna em aço inox 304;
- Registro de esfera para o escoamento da água e do óleo;
- Dois rodízios dianteiros com trava e dois traseiros sem trava.

medidas totais (AxLxP)	peso líq.	consumo médio	capacidade		
			óleo	água	sal
869 x 789 x 496 mm	34,8 kg	1 kg/h	30 l	6 l	500 g



**FRITADOR ÁGUA E ÓLEO PR-90 E**

- Registro de esfera para o escoamento da água e do óleo;
- Resistência em aço inox blindada e termostato para controle de temperatura.

medidas totais (AxLxP)	peso líq.	consumo médio		capacidade		
		127 V	220 V	óleo	água	sal
950 x 593 x 592 mm	9,9 kg	2,5 kWh		12 l	7 l	400 g

**FRITADOR ÁGUA E ÓLEO PR-100 E STYLE**

- Cuba interna em aço inox 304;
- Registro de esfera para o escoamento da água e do óleo, e termostato para controle de temperatura.

medidas totais (AxLxP)	peso líq.	consumo médio		capacidade		
		127 V	220 V	óleo	água	sal
384 x 395 x 540 mm	8,1 kg	2,5 kWh	3,5 kWh	13 l	5 l	500 g

**FRITADOR ÁGUA E ÓLEO PR-200 E**

- Cuba interna em aço inox 304;
- Registro de esfera para o escoamento da água e do óleo;
- Resistência em aço inox blindada e termostato para controle de temperatura;
- Dois rodízios dianteiros com trava e dois traseiros sem trava.

medidas totais (AxLxP)	peso líq.	consumo médio		capacidade		
		127 V	220 V	óleo	água	sal
967 x 790 x 450 mm	15,1 kg	2x 2,5 kWh	2x 3,5 kWh	2x (13)	2x (5)	500 g

**FRITADOR ÁGUA E ÓLEO PR-300 E STYLE**

- Cuba interna em aço inox 304;
- Registro de esfera para o escoamento da água e do óleo, resistência em aço inox blindada e termostato para controle de temperatura;
- Dois rodízios dianteiros com trava e dois traseiros sem trava.

medidas totais (AxLxP)	peso líq.	consumo médio		capacidade		
		127 V	220 V	óleo	água	sal
1078 x 395 x 526 mm	12,5 kg	3,5 kWh		24 l	5 l	500 g



**FRITADOR ÁGUA E ÓLEO PR-2000 E STYLE**

- Cuba interna em aço inox 304;
- Registro de esfera para o escoamento da água e do óleo;
- Resistência em aço inox blindada e termostato para controle de temperatura;
- Dois rodízios dianteiros com trava e dois traseiros sem trava.

medidas totais (AxLxP)	peso líq.	consumo médio	capacidade		
			óleo	água	sal
974 x 588 x 549 mm	15,1 kg	3,5 kWh	22 l	4 l	400 g

**FRITADOR ELETRÔNICO PR-2000 EL**

- Controle digital de tempo e temperatura;
- Cuba interna em aço inox 304;
- Fácil programação;
- Dois rodízios dianteiros com trava e dois traseiros sem trava.

medidas totais (AxLxP)	capacidade			peso líq.	consumo médio
	óleo	água	sal		
974 x 581 x 549 mm	22 l	4 l	400 g	15,1 kg	3,5 kWh

**FRITADOR ELETRÔNICO PR-2008 EL**

- Controle digital de tempo e temperatura com fácil programação;
- Cuba interna em aço inox 304;
- Dois rodízios dianteiros com trava e dois traseiros sem trava;
- Chave de aumento de potência: 5000 W para 8000 W.

medidas totais (AxLxP)	capacidade			peso líq.	consumo médio
	óleo	água	sal		
974 x 575 x 550 mm	22 l	4 l	400 g	16,7 kg	4,5 kWh

**FRITADOR ÁGUA E ÓLEO PR-3000 E STYLE**

- Cuba interna em aço inox 304;
- Registro de esfera para o escoamento da água e do óleo;
- Resistência em aço inox blindada e termostato para controle de temperatura;
- Dois rodízios dianteiros com trava e dois traseiros sem trava.

medidas totais (AxLxP)	peso líq.	consumo médio	capacidade		
			óleo	água	sal
974 x 873 x 547 mm	20,1 kg	4,2 kWh	36 l	6 l	500 g



**FRITADOR ELETRÔNICO PR-3000 EL**

- Controle digital de tempo e temperatura;
- Fácil programação;
- Cuba em aço inox;
- Dois rodízios dianteiros com trava e dois traseiros sem trava.

medidas totais (A x L x P)	peso líq.	consumo médio	capacidade		
			óleo	água	sal
974 x 872 x 547 mm	20,1 kg	4,2 kWh	36 l	6 l	500 g

**FRITADOR ELETRÔNICO PR-3008 EL**

- Controle digital de tempo e temperatura;
- Fácil programação;
- Cuba em aço inox;
- Dois rodízios dianteiros com trava e dois traseiros sem trava;
- Chave de aumento de potência: 5000 W para 8000 W.

medidas totais (A x L x P)	peso líq.	consumo médio	capacidade		
			óleo	água	sal
974 x 872 x 547 mm	22 kg	5,6 kWh	36 l	6 l	500 g

**ACESSÓRIOS OPCIONAIS:****CESTO SIMPLES**

Dimensões (A x L x P): 90 x 110 x 325 mm

Capacidade: 0,5 kg

Acompanha os modelos: PR-3000 BPAT, PR-3000 BPG, PR-3008 EL, PR-3008 E, PR-3000 EL, PR-3000 E, PR-2008 EL, PR-2008 E, PR-2000 E, PR-2000 EL, PR-2000 BPG e PR-2000 BPAT.

Dimensões (A x L x P): 90 x 130 x 250 mm

Capacidade: 0,25 kg

Acompanha os modelos: PR-100 E, PR-200 E, PR-300 E e PR-300 G2.

Dimensões (A x L x P): 130 x 145 x 365 mm

Capacidade: 1 kg

Acompanha os modelos: PFAP-45 e PRF-45 E.

CESTO DUPLO

Dimensões (A x L x P): 95 x 330 x 325 mm

Capacidade: 1 kg

Acompanha os modelos: PR-3000 BPAT, PR-3000 BPG, PR-3000 E e PR 3000 EL.



CORTADORES DE LEGUMES



Com dispositivo que corta as batatas em palitos de 10 x 10 mm

CORTADOR DE LEGUMES PROGUITA

medidas totais (AxLxP)	peso líq.
525 x 230 x 325 mm	1,5 kg



Com dispositivo que corta as batatas em palitos de 10 x 10 mm

CORTADOR DE LEGUMES PROGUITA COM PEDESTAL

medidas totais (AxLxP)	peso líq.
1095 x 450 x 500 mm	4 kg



ACESSÓRIO:



KIT PURÊ

Dispositivo que amassa legumes. Não é vendido separadamente.





ESTUFAS

**ESTUFA CURVA ELÉTRICA PRV-03 E**

medidas totais (AxLxP)	peso liq.	consumo médio
349 x 471 x 374 mm	7,3 kg	0,19 kWh

**ESTUFA CURVA ELÉTRICA PRV-04 E**

medidas totais (AxLxP)	peso liq.	consumo médio
349 x 621 x 374 mm	9,6 kg	0,19 kWh





ESTUFA CURVA ELÉTRICA PRV-05 E

medidas totais (AxLxP)	peso líq.	consumo médio
349 x 771 x 374 mm	11,6 kg	0,38 kWh



ESTUFA CURVA ELÉTRICA PRV-06 DE

medidas totais (AxLxP)	peso líq.	consumo médio
448 x 471 x 374 mm	9,2 kg	0,19 kWh



ESTUFA VERTICAL PR-640 E

• Com resistência blindada e termostato.

medidas totais (AxLxP)	peso líq.	consumo médio
622 x 416 x 390 mm	12,4 kg	0,19 kWh



ESTUFA VERTICAL PR-640 VI

medidas totais (AxLxP)	peso líq.
622 x 384 x 390 mm	12,1 kg





MISTURADORES





MISTURADORES MOGMIX PRMOG-07



- Ideais para doces que precisam ser mexidos constantemente, como brigadeiros, geleias, doces de colher e muito mais;
- Com controle de troca de velocidades continuamente variável;
- Disponível nas cores: alumínio, amarela e vermelha;
- Cabeçote em aço inox e caçarola em alumínio fundido.

modelo	capacidade	peso líq.	consumo médio	medidas totais (AxLxP)
PRMOG-07	7 l	7 kg	0,025 kWh	310 x 385 x 315 mm



Saiba mais sobre o MogMix.
Aponte seu leitor de QR Code e assista ao vídeo.



MISTURADORES MOGMIX PRMOG-05



- Ideais para doces que precisam ser mexidos constantemente, como brigadeiros, geleias, doces de colher e muito mais;
- Com controle de troca de velocidades continuamente variável;
- Disponível nas cores: alumínio, amarela e vermelha;
- Cabeçote em aço inox e caçarola em alumínio fundido.

modelo	capacidade	peso líq.	consumo médio	medidas totais (AxLxP)
PRMOG-05	5 l	5,6 kg	0,025 kWh	290 x 372 x 285 mm



Saiba mais sobre o MogMix.
Aponte seu leitor de QR Code e assista ao vídeo.



ACESSÓRIO OPCIONAL:



GIRAMOG-07 / 05

- Suporte para ser usado junto ao MogMix.



medidas totais (AxLxP)	peso líq.
362 x 547 x 304 mm	3,6 kg

* Os misturadores não acompanham este produto;
** Disponível na cor branca.



Saiba mais sobre a GiraMog.
Aponte seu leitor de QR Code e assista ao vídeo.

**MISTURADOR MOGMIX PRMOG-07 E**

- Ideais para doces que precisam ser mexidos constantemente, como brigadeiros, geleias, doces de colher e muito mais;
- Com controle de troca de velocidades continuamente variável.

modelo	medidas totais (AxLxP)	peso líq.	consumo médio
PRMOG-07 E	430 x 385 x 315 mm	11 kg	1,5 kWh



Controle digital de tempo com sinal sonoro



Elétrico: 127 ou 220 V



Saiba mais sobre o PRMQ-10 cooktop.
Aponte seu leitor de QR Code e assista ao vídeo.

MISTURADOR COMPACTO THE MIX PRMQ-10 COOKTOP

- Capacidade para misturar até 4 kg de massa pronta;
- Ideal para massa de coxinha.

medidas totais (AxLxP)	peso líq.	consumo médio	capacidade
337 x 404 x 353 mm	8,3 kg	0,18 kWh	10 l



Controle digital de tempo com sinal sonoro

Produto ideal para massa de coxinha

Grade de proteção cromada

Tacho basculante em alumínio fundido



Pés antiderrapantes

MISTURADOR COMPACTO THE MIX PRMQ-10

- Capacidade para misturar até 4 kg de massa pronta;
- Ideal para massa de coxinha.

medidas totais (AxLxP)	peso líq.	consumo médio	capacidade
545 x 528 x 353 mm	14,4 kg	0,18 kWh	10 l





MISTURADOR THE MIX PRMQ-15

- Misturador de baixa rotação, ideal para preparar geleias, cremes, polenta e massa para salgados;
- Carenagem em polímero termoformado de alta resistência;
- Com tacho basculante em alumínio fundido e queimador simples chama dupla ø 120 mm.

medidas totais (AxLxP)	peso liq.	motor	consumo médio
1033 x 670 x 580 mm	34 kg	monof. 1/4 CV	0,18 kWh



MISTURADOR THE MIX PRMQ-22

- Misturador de baixa rotação, ideal para preparar geleias, cremes, polenta e massa para salgados;
- Carenagem em polímero termoformado de alta resistência;
- Com tacho basculante em alumínio fundido e queimador simples chama dupla ø 120 mm.

medidas totais (AxLxP)	peso liq.	motor	consumo médio
1033 x 670 x 570 mm	42 kg	monof. 1/4 CV	0,18 kWh



MISTURADOR THE MIX PRMQI-25

- Misturador de baixa rotação, ideal para preparar geleias, cremes, polenta e massa para salgados;
- Carenagem em polímero termoformado de alta resistência;
- Com tacho basculante em aço inox e queimador simples chama dupla ø 120 mm.

medidas totais (AxLxP)	peso liq.	motor	consumo médio
1033 x 670 x 570 mm	38 kg	monof. 1/2 CV	0,37 kWh



MISTURADOR THE MIX PRMQ-40

- Misturador de baixa rotação, ideal para preparar geleias, cremes, polenta e massa para salgados;
- Carenagem em polímero termoformado de alta resistência;
- Com tacho basculante em alumínio fundido e queimador duplo ø 200 mm.

medidas totais (AxLxP)	peso liq.	motor	consumo médio
1168 x 680 x 610 mm	53 kg	monof. 1/2 CV	0,37 kWh





FOGÕES





Saiba mais sobre o PRGE-402 F Gourmet. Aponte seu leitor de QR Code e assista ao vídeo.



2 queimadores simples chama dupla ø 120 mm



2 queimadores duplos ø 160 mm

FOGÃO INDUSTRIAL PRGE-402 F GOURMET

- Estrutura em aço com acabamento em pintura epóxi;
- Acompanha forno FGE-110 Gourmet, com capacidade de 80 litros.



medidas totais (Fornos)	medidas totais (AxLxP)	consumo médio	peso líq.
437 x 638 x 813 mm	823 x 872 x 842 mm	1,6 kg/h	64,5 kg

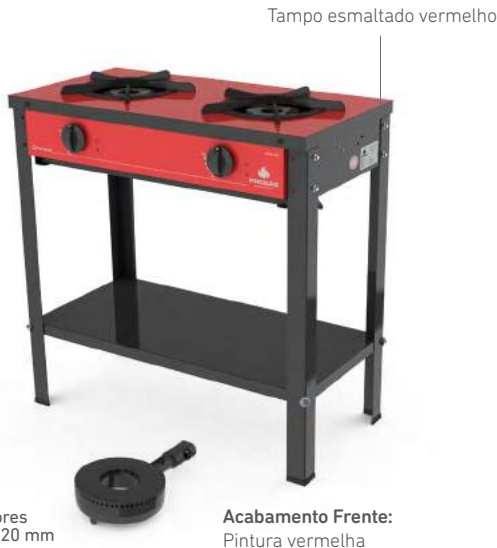

FOGÃO INDUSTRIAL PRGE-200 GOURMET

- Versão 2 bocas.

medidas totais (AxLxP)	consumo médio	peso líq.
823 x 813 x 437 mm	0,6 kg/h	23,5 kg



*painel e tampo.

FORNO FGE-110 GOURMET

- Estrutura em aço e isolamento térmico em lã basáltica.

medidas totais Externas (AxLxP)	medidas totais Internas (AxLxP)	peso líq.	capacidade
437 x 638 x 813 mm (com cavalete)	250 x 455 x 700 mm	34,8 kg	80 L



*portas dos fornos.



1 queimador duplo ø 200 mm

FOGÃO PMD-100

- Produzido com perfil de 9 cm e grelhas removíveis em material fundido de 43 x 43 cm;
- Registros industriais em latão cromado com estágios contínuos;
- Com bandeja coletora de gordura e sapatas plásticas.

medidas totais (A x L x P)	peso líq.
825 x 605 x 670 mm	26 kg



2 queimadores duplos ø 200 mm

FOGÃO PMD-200 F LINHA

- Produzido com perfil de 9 cm e grelhas removíveis em material fundido de 43 x 43 cm;
- Registros industriais em latão cromado com estágios contínuos;
- Com bandeja coletora de gordura e sapatas plásticas.

medidas totais (A x L x P)	peso líq.
825 x 1105 x 670 mm	42,2 kg



3 queimadores duplos ø 200 mm

FOGÃO PMD-300 F

- Produzido com perfil de 9 cm e grelhas removíveis em material fundido de 43 x 43 cm;
- Registros industriais em latão cromado com estágios contínuos;
- Com bandeja coletora de gordura e sapatas plásticas.

medidas totais (A x L x P)	peso líq.
825 x 1605 x 670 mm	58,3 kg



4 queimadores duplos ø 200 mm

FOGÃO PMD-400 F

- Produzido com perfil de 9 cm e grelhas removíveis em material fundido de 43 x 43 cm;
- Registros industriais em latão cromado com estágios contínuos;
- Com bandeja coletora de gordura e sapatas plásticas.

modelo	medidas totais (A x L x P)	peso líq.
PMD-400 F (de centro)	825 x 1105 x 1250 mm	75 kg
PMD-400 F ENCOSTO (de encosto)	825 x 1105 x 1165 mm	





6 queimadores duplos Ø 200 mm

FOGÃO PMD-600 F

- Produzido com perfil de 9 cm e grelhas removíveis em material fundido de 43 x 43 cm;
- Registros industriais em latão cromado com estágios contínuos;
- Com bandeja coletora de gordura e sapatas plásticas.

modelo	medidas totais (AxLxP)	peso liq.
PMD-600 F (de centro)	825 x 1605 x 1250 mm	110 kg
PMD-600 F ENCOSTO (de encosto)	825 x 1605 x 1165 mm	109 kg



ACESSÓRIOS OPCIONAIS DA LINHA PMD:



MÓDULO PARA BANHO-MARIA PMD-MBM C/ BMI
Dimensões (AxLxP): 985 x 605 x 1170 mm (28 kg)

SUPORTE PARA MÓDULO PMD-MBM S/ BMI
Dimensões (AxLxP): 870 x 605 x 1170 mm (21,5 kg)



MÓDULO CHAPA PMD-MCH
Dimensões (AxLxP): 895 x 615 x 1180 mm (36 kg)



BANHO-MARIA SEM SUPORTE BMI P/ PMD
Dimensões (AxLxP): 115 x 540 x 990 mm (7 kg)

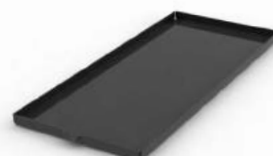

CHAPA SEM SUPORTE
Dimensões (AxLxP): 25 x 430 x 1030 mm (14,5 kg)



FORNO FSI-680 N

Estrutura em aço e isolamento térmico com lã basáltica.

Dimensões (AxLxP): 363 x 556 x 725 mm (21 kg)

Capacidade em litros: 67 L - útil

Medidas internas (AxLxP): 260 x 505 x 650 mm

Disponível para:
PMD-200 F LINHA, PMD-300 F, PMD-400 F e PMD-600 F.



Com termômetro e faiscador

FORNO FSP-6800 AT

Isolamento térmico com lã basáltica e placa refratária que conserva o calor dentro do forno, ajudando na economia de gás.

Dimensões (AxLxP): 428 x 600 x 733 mm (32,5 kg)

Capacidade em litros: 67 L - útil

Medidas internas (AxLxP): 250 x 505 x 660 mm

Disponível para:
PMD-200 F LINHA, PMD-300 F, PMD-400 F e PMD-600 F.



1 queimador simples
chama dupla ø 120 mm**FOGÃO PMS-100**

- Produzido com perfil de 5 cm e grelha removível em material fundido de 33 x 33 cm;
- Registros industriais com estágios contínuos;
- Com bandeja coletora de gordura e sapatas plásticas.

medidas totais (AxLxP)	peso líq.
880 x 395 x 490 mm	13 kg

Com grelha
paralela1 queimador
duplo ø 200 mm**FOGÃO PMS-110**

- Modulável com todos os fogões das linhas PMS e PMSD;
- Produzido com perfil de 5 cm e grelha paralela removível;
- Registros industriais com estágios contínuos;
- Com bandeja coletora de gordura e sapatas plásticas.

medidas totais (AxLxP)	peso líq.
880 x 510 x 820 mm	22 kg

2 queimadores simples
chama dupla ø 120 mm**FOGÃO PMS-200**

- Produzido com perfil de 5 cm e grelhas removíveis em material fundido de 33 x 33 cm;
- Registros industriais com estágios contínuos;
- Com bandeja coletora de gordura e sapatas plásticas.

medidas totais (AxLxP)	peso líq.
880 x 740 x 490 mm	18,5 kg

3 queimadores simples
chama dupla ø 120 mm**FOGÃO PMS-300**

- Produzido com perfil de 5 cm e grelhas removíveis em material fundido de 33 x 33 cm;
- Registros industriais com estágios contínuos;
- Com bandeja coletora de gordura e sapatas plásticas.

medidas totais (AxLxP)	peso líq.
880 x 1085 x 490 mm	24,5 kg





4 queimadores simples
chama dupla ø 120 mm

FOGÃO PMS-400 FCH

- Produzido com perfil de 5 cm e grelhas removíveis em material fundido de 33 x 33 cm;
- Registros industriais com estágios contínuos;
- Com bandeja coletora de gordura e sapatas plásticas.

modelo	medidas totais (AxLxP)	peso líq.
PMS-400 F (sem chapa)	880 x 740 x 820 mm	28,5 kg
PMS-400 FCH (com chapa)	895 x 1085 x 845 mm	43 kg



6 queimadores simples
chama dupla ø 120 mm

FOGÃO PMS-600 FCH

- Produzido com perfil de 5 cm e grelhas removíveis em material fundido de 33 x 33 cm;
- Registros industriais com estágios contínuos;
- Com bandeja coletora de gordura e sapatas plásticas.

modelo	medidas totais (AxLxP)	peso líq.
PMS-600 F (sem chapa)	880 x 1085 x 820 mm	41,5 kg
PMS-600 FCH (com chapa)	895 x 1430 x 845 mm	59,5 kg



1 queimador duplo ø 200 mm
4 queimadores simples
chama dupla ø 120 mm

FOGÃO PMS-510 FCH

- Produzido com perfil de 5 cm, com grelhas removíveis em material fundido de 33 x 33 cm e grelha paralela;
- Registros industriais com estágios contínuos;
- Com bandeja coletora de gordura e sapatas plásticas.

modelo	medidas totais (AxLxP)	peso líq.
PMS-510 F (sem chapa)	880 x 1195 x 820 mm	44,5 kg
PMS-510 FCH (com chapa)	895 x 1540 x 845 mm	59 kg





ACESSÓRIOS OPCIONAIS DA LINHA PMS:

**MÓDULO PARA BANHO-MARIA PMS-MBM C/ BMSI**

Dimensões (AxLxP): 980 x 395 x 830 mm (18 kg)

SUPORTE PARA MÓDULO PMS-MBM S/ BMSI

Dimensões (AxLxP): 865 x 395 x 820 mm (13 kg)

**MÓDULO CHAPA PMS-MCH**

Dimensões (AxLxP): 890 x 395 x 845 mm (20,5 kg)

**BANHO-MARIA SEM SUPORTE BMSI P/ PMS**

Dimensões (AxLxP): 115 x 390 x 740 mm (5 kg)

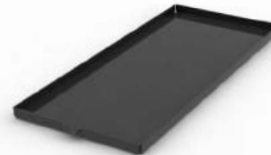
**CHAPA SEM SUPORTE**

Dimensões (AxLxP): 25 x 315 x 720 mm (7 kg)

**FORNO FSI-500 N**

Estrutura em aço e isolamento térmico com lâ basáltica.

Dimensões (AxLxP): 363 x 556 x 570 mm (15,5 kg)**Capacidade em litros:** 49,5 L - útil**Medidas internas (AxLxP):** 265 x 505 x 480 mmDisponível para o modelo:
PMS-200 F.**FORNO FSI-680 N**

Estrutura em aço e isolamento térmico com lâ basáltica.

Dimensões (AxLxP): 363 x 556 x 725 mm (21 kg)**Capacidade em litros:** 67 L - útil**Medidas internas (AxLxP):** 260 x 505 x 650 mmDisponível para:
PMS-400 F, PMS-600 F e PMS-510 F.Com termômetro e
faiscador**FORNO FSP-6800 AT**

Isolamento térmico com lâ basáltica e placa refratária que conserva o calor dentro do forno, ajudando na economia de gás.

Dimensões (AxLxP): 428 x 600 x 733 mm (32,5 kg)**Capacidade em litros:** 67 L - útil**Medidas internas (AxLxP):** 250 x 505 x 660 mmDisponível para:
PMS-400 N, PMS-400 NCH, PMS-600 N,
PMS-600 NCH, PMS-510 N e PMS-510 NCH.



1 queimador duplo ø 160 mm

FOGÃO PMSD-101

- Produzido com perfil de 5 cm e grelhas removíveis em material fundido de 33 x 33 cm;
- Registros industriais com estágios contínuos;
- Com bandeja coletora de gordura e sapatas plásticas.

medidas totais (A x L x P)	peso líq.
880 x 395 x 490 mm	14 kg



1 queimador duplo ø 160 mm 1 queimador simples chama dupla ø 120 mm

FOGÃO PMSD-201 F

- Produzido com perfil de 5 cm e grelhas removíveis em material fundido de 33 x 33 cm;
- Registros industriais com estágios contínuos;
- Com bandeja coletora de gordura e sapatas plásticas.

medidas totais (A x L x P)	peso líq.
880 x 740 x 490 mm	19 kg



2 queimadores duplos ø 160 mm

FOGÃO PMSD-202

- Produzido com perfil de 5 cm e grelhas removíveis em material fundido de 33 x 33 cm;
- Registros industriais com estágios contínuos;
- Com bandeja coletora de gordura e sapatas plásticas.

medidas totais (A x L x P)	peso líq.
880 x 740 x 490 mm	20 kg



1 queimador duplo ø 160 mm 2 queimadores simples chama dupla ø 120 mm

FOGÃO PMSD-301 F

- Produzido com perfil de 5 cm e grelhas removíveis em material fundido de 33 x 33 cm;
- Registros industriais com estágios contínuos;
- Com bandeja coletora de gordura e sapatas plásticas.

medidas totais (A x L x P)	peso líq.
880 x 1085 x 490 mm	25,5 kg





2 queimadores duplos ø 160 mm 2 queimadores simples chama dupla ø 120 mm

FOGÃO PMSD-402 F

- Produzido com perfil de 5 cm e grelhas removíveis em material fundido de 33 x 33 cm;
- Registros industriais com estágios contínuos;
- Com bandeja coletora de gordura e sapatas plásticas.

modelo	medidas totais (AxLxP)	peso líq.
PMSD-402 F (sem chapa)	880 x 740 x 820 mm	30 kg
PMSD-402 FCH (com chapa)	895 x 1085 x 845 mm	45 kg



3 queimadores duplos ø 160 mm 3 queimadores simples chama dupla ø 120 mm

FOGÃO PMSD-603 FCH

- Produzido com perfil de 5 cm e grelhas removíveis em material fundido de 33 x 33 cm;
- Registros industriais com estágios contínuos;
- Com bandeja coletora de gordura e sapatas plásticas.

modelo	medidas totais (AxLxP)	peso líq.
PMSD-603 F (sem chapa)	880 x 1085 x 820 mm	44 kg
PMSD-603 FCH (com chapa)	895 x 1430 x 845 mm	62 kg



1 queimador duplo ø 200 mm



2 queimadores duplos ø 160 mm



2 queimadores simples chama dupla ø 120 mm

**FOGÃO PMSD-512 F**

- Produzido com perfil de 5 cm, com grelhas removíveis em material fundido de 33 x 33 cm e grelha paralela;
- Registros industriais com estágios contínuos;
- Com bandeja coletora de gordura e sapatas plásticas.

medidas totais (AxLxP)	peso líq.
880 x 1195 x 820 mm	46 kg





ACESSÓRIOS OPCIONAIS DA LINHA PMSD:



MÓDULO PARA BANHO-MARIA PMS-MBM C/ BMSI

Dimensões (AxLxP): 980 x 395 x 830 mm (18 kg)

SUPOORTE PARA MÓDULO PMS-MBM S/ BMSI

Dimensões (AxLxP): 865 x 395 x 820 mm (13 kg)



MÓDULO CHAPA PMS-MCH

Dimensões (AxLxP): 890 x 395 x 845 mm (20,5 kg)



BANHO-MARIA SEM SUPOORTE BMSI P/ PMS

Dimensões (AxLxP): 115 x 390 x 740 mm (5 kg)

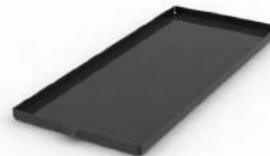

CHAPA SEM SUPOORTE

Dimensões (AxLxP): 25 x 315 x 720 mm (7 kg)



FORNO FSI-500 N

Estrutura em aço e isolamento térmico com lã basáltica.

Dimensões (AxLxP): 363 x 556 x 570 mm (15,5 kg)

Capacidade em litros: 49,5 L - útil

Medidas internas (AxLxP): 265 x 505 x 480 mm

Disponível para o modelo: PMSD-201 E e PMSD-301 F.



FORNO FSI-680 N

Estrutura em aço e isolamento térmico com lã basáltica.

Dimensões (AxLxP): 363 x 556 x 725 mm (21 kg)

Capacidade em litros: 67 L - útil

Medidas internas (AxLxP): 260 x 505 x 650 mm

Disponível para: PMSD-402 F, PMSD-603 F e PMS-512 F.



Com termômetro e físcador

FORNO FSP-6800 AT

Isolamento térmico com lã basáltica e placa refratária que conserva o calor dentro do forno, ajudando na economia de gás.

Dimensões (AxLxP): 428 x 600 x 733 mm (32,5 kg)

Capacidade em litros: 67 L - útil

Medidas internas (AxLxP): 250 x 505 x 660 mm

Disponível para: PMSD-402 F, PMSD-603 F, PMSD-603 FCH e PMSD-512 F.





2 queimadores
simples \varnothing 100 mm

FOGÃO PM-200

- Produzido com perfil de 3 cm e grelhas em material fundido de 33 x 33 cm;
- Registros semi-industriais com estágios contínuos;
- Com bandeja coletora de gordura.

medidas totais (AxLxP)	peso líq.
815 x 675 x 455 mm	15 kg



4 queimadores
simples \varnothing 100 mm

FOGÃO PM-400 F

- Produzido com perfil de 3 cm e grelhas em material fundido de 33 x 33 cm;
- Registros semi-industriais com estágios contínuos;
- Com bandeja coletora de gordura.

medidas totais (AxLxP)	peso líq.
815 x 675 x 780 mm	24 kg

**ACESSÓRIO OPCIONAL DA LINHA PM:****FORNO FSI-500 N**

Estrutura em aço e isolamento térmico com lâ basáltica.

Dimensões (AxLxP): 363 x 556 x 570 mm (15,5 kg)

Capacidade em litros: 49,5 L - útil

Medidas internas (AxLxP): 265 x 505 x 480 mm

Disponível para o modelo:
PM-400 F.





1 queimador
simples ø 100 mm

FOGÃO PREA-100 M

- Produzido com perfil de 3 cm e grelha paralela removível;
- Com bandeja coletora de gordura.

medidas totais (AxLxP)	peso líq.
155 x 350 x 455 mm	10,5 kg



2 queimadores
simples ø 100 mm

FOGÃO PREA-200

- Produzido com perfil de 3 cm e grelha paralela removível;
- Com bandeja coletora de gordura.

medidas totais (AxLxP)	peso líq.
810 x 675 x 445 mm	11 kg



3 queimadores
simples ø 100 mm

FOGÃO PREA-300

- Produzido com perfil de 3 cm e grelhas paralelas removíveis;
- Com bandeja coletora de gordura.

medidas totais (AxLxP)	peso líq.
810 x 1000 x 445 mm	22 kg



4 queimadores
simples ø 100 mm

FOGÃO PREA-400 F

- Produzido com perfil de 3 cm e grelhas paralelas removíveis;
- Com bandeja coletora de gordura.

medidas totais (AxLxP)	peso líq.
810 x 675 x 770 mm	19 kg





2 queimadores
simples ø 100 mm

FOGÃO PREA-200 FF

- Produzido com perfil de 3 cm e grelhas removíveis em material fundido com 33 x 33 cm;
- Com bandeja coletora de gordura.

medidas totais (AxLxP)	peso líq.
815 x 675 x 455 mm	15 kg



3 queimadores
simples ø 100 mm

FOGÃO PREA-300 FF

- Produzido com perfil de 3 cm e grelhas removíveis em material fundido com 33 x 33 cm;
- Com bandeja coletora de gordura.

medidas totais (AxLxP)	peso líq.
810 x 1000 x 445 mm	20,5 kg



4 queimadores
simples ø 100 mm

FOGÃO PREA-400 F FF

- Produzido com perfil de 3 cm e grelhas removíveis em material fundido com 33 x 33 cm;
- Com bandeja coletora de gordura.

medidas totais (AxLxP)	peso líq.
815 x 675 x 780 mm	24 kg

**ACESSÓRIO OPCIONAL DA LINHA PREA:****FORNO FSIA-500 N**

Estrutura em aço e isolamento térmico com lâ basáltica.

Dimensões (AxLxP): 363 x 556 x 570 mm (15,5 kg)

Capacidade em litros: 49,5 L - útil

Medidas internas (AxLxP): 265 x 505 x 480 mm

Disponível para o modelo:
PREA-400 F.





4 queimadores simples
chama dupla ø 120 mm

FOGÃO INOX PMI-400 F

- Produzido com perfil de 5 cm e grelhas removíveis em material fundido com 33 x 33 cm;
- Registros industriais com estágios contínuos;
- Com bandeja coletora de gordura e sapatas plásticas.

medidas totais (A x L x P)	peso líq.
880 X 740 X 820 mm	29 kg



2 queimadores
duplos ø 160 mm

2 queimadores simples
chama dupla ø 120 mm

FOGÃO INOX PMI-402 F

- Produzido com perfil de 5 cm e grelhas removíveis em material fundido com 33 x 33 cm;
- Registros industriais com estágios contínuos;
- Com bandeja coletora de gordura e sapatas plásticas.

medidas totais (A x L x P)	peso líq.
880 x 740 x 820 mm	30 kg



3 queimadores
duplos ø 160 mm

3 queimadores simples
chama dupla ø 120 mm

FOGÃO INOX PMI-603 F

- Produzido com perfil de 5 cm e grelhas removíveis em material fundido com 33 x 33 cm;
- Registros industriais com estágios contínuos;
- Com bandeja coletora de gordura e sapatas plásticas.

medidas totais (A x L x P)	peso líq.
880 x 1085 x 820 mm	44 kg





6 queimadores simples
chama dupla \varnothing 120 mm

FOGÃO INOX PMI-600 F

- Produzido com perfil de 5 cm e grelhas em material fundido com 33 x 33 cm;
- Registros industriais com estágios contínuos;
- Com bandeja coletora de gordura e sapatas plásticas.

medidas totais (AxLxP)	peso líq.
880 x 1085 x 820 mm	41,3 kg

**ACESSÓRIOS OPCIONAIS DA LINHA PMI:****MÓDULO PARA BANHO-MARIA PMI-MBM C/ BMI**

Dimensões (AxLxP): 980 x 395 x 830 mm (18 kg)

SUPOORTE PARA MÓDULO PMI-MBM S/ BMI

Dimensões (AxLxP): 865 x 395 x 820 mm (13 kg)

**MÓDULO CHAPA PMI-MCH**

Dimensões (AxLxP): 890 x 395 x 845 mm (20,5 kg)

**BANHO-MARIA SEM SUPOORTE BMSI P/ PMS**

Dimensões (AxLxP): 115 x 390 x 740 mm (5 kg)

**CHAPA SEM SUPOORTE**

Dimensões (AxLxP): 25 x 315 x 720 mm (7kg)

**FORNO FSI-680 NI**

Estrutura em aço inox escovado e isolamento térmico com lã de rocha.

Dimensões (AxLxP): 363 x 556 x 725 mm (17,1 kg)

Capacidade em litros: 67 L - útil

Medidas internas (AxLxP): 260 x 505 x 650 mm

Disponível para:

PMI-400 F, PMI-402 F, PMI-600 F e PMI-603 F.





2 queimadores duplos ø 200 mm

FOGÃO INOX PMDI-200 LINHA

- Produzido com perfil reforçado de 9 cm e grelhas em material fundido de 43 x 43 cm;
- Registros de estágios contínuos;
- Com sapatas plásticas.

medidas totais (A x L x P)	peso líq.
825 x 1105 x 670 mm	40 kg



4 queimadores duplos ø 200 mm

FOGÃO INOX PMDI-400 F

- Produzido com perfil reforçado de 9 cm e grelhas em material fundido de 43 x 43 cm;
- Registros de estágios contínuos;
- Com sapatas plásticas.

modelo	medidas totais (A x L x P)	peso líq.
PMDI-400 F (de centro)	825 x 1105 x 1250 mm	74 kg
PMDI-400 F ENCOSTO (de encosto)	825 x 1105 x 1165 mm	73 kg



6 queimadores duplos ø 200 mm

FOGÃO INOX PMDI-600 F

- Produzido com perfil reforçado de 9 cm e grelhas em material fundido de 43 x 43 cm;
- Registros de estágios contínuos;
- Com sapatas plásticas.

modelo	medidas totais (A x L x P)	peso líq.
PMDI-600 F (de centro)	825 x 1605 x 1250 mm	108 kg
PMDI-600 F ENCOSTO (de encosto)	825 x 1605 x 1165 mm	106 kg





ACESSÓRIOS OPCIONAIS DA LINHA PMDI:

**MÓDULO PARA BANHO-MARIA PMDI-MBM C/ BMI**

Dimensões (AxLxP): 985 x 605 x 1170 mm (27 kg)

**SUPORTE PARA MÓDULO PMDI-MBM S/ BMI**

Dimensões (AxLxP): 870 x 605 x 1170 mm (20 kg)

**MÓDULO CHAPA PMDI-MCH**

Dimensões (AxLxP): 895 x 615 x 1180 mm (34,5 kg)

**BANHO-MARIA SEM SUPORTE BMI P/ PMDI**

Dimensões (AxLxP): 115 x 540 x 990 mm (7 kg)

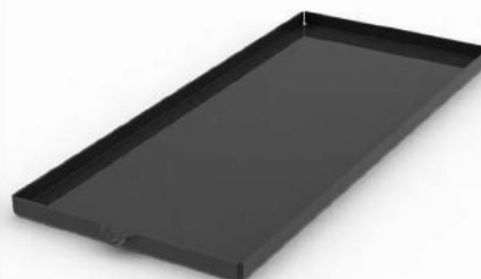
**CHAPA SEM SUPORTE**

Dimensões (AxLxP): 25 x 430 x 1030 (14,5 kg)

**FORNO FSI-680 NI**

Estrutura em aço inox escovado e isolamento térmico com lã de rocha.

Dimensões (AxLxP): 363 x 556 x 725 mm (17,1 kg)

Capacidade em litros: 67 L - útil

Medidas internas (AxLxP): 260 x 505 x 650 mm

Disponível para:
PMDI-400 F e PMDI-600 F.



1 queimador tripla ø 420 mm

Fogão mais baixo: conforto e segurança para o usuário



2 queimadores triplos ø 420 mm

Fogão mais baixo: conforto e segurança para o usuário

FOGÃO PFI-100

- Fogão desenvolvido para suportar panelas de aprox. ø 600 mm;
- Produzido com perfil reforçado de 5 cm e grelhas paralelas super reforçadas de 710 x 640 mm;
- Registros de alta pressão com estágios contínuos e comandos individuais para cada queimador;
- Com sapatas plásticas.

medidas totais (A x L x P)	peso líq.
525 x 745 x 850 mm	46 kg



FOGÃO PFI-200

- Fogão desenvolvido para suportar panelas de aprox. ø 600 mm;
- Produzido com perfil reforçado de 5 cm e grelhas paralelas super reforçadas de 710 x 640 mm;
- Registros de alta pressão com estágios contínuos e comandos individuais para cada queimador;
- Com sapatas plásticas.

medidas totais (A x L x P)	peso líq.
525 x 1485 x 850 mm	77 kg



QUEIMADORES:

- Produzidos em material fundido com fixação através de encaixe.



Queimador simples ø 100 mm



Queimador simples chama dupla ø 120 mm



Queimador duplo ø 160 mm



Queimador duplo ø 200 mm



Queimador tripla ø 420 mm

TABELA DE CONSUMO DE GÁS POR QUEIMADOR:

queimador	consumo médio
Queimador FSI	0,3 kg/h
Queimador para Chapa PMS	0,3 kg/h
Queimador para Chapa PMD	0,34 kg/h
Queimador Simples ø 100 mm	0,25 kg/h
Queimador Simples Chama Dupla ø 120 mm	0,3 kg/h

queimador	consumo médio
Queimador Duplo ø 160 mm	0,5 kg/h
Queimador Duplo ø 200 mm	0,6 kg/h
Queimador Caulim 3 chamas	0,2 kg/h
Queimador Caulim 7 chamas	0,43 kg/h
Queimador Tripla ø 420 mm	1,1 kg/h

**FOGÃO INDUSTRIAL DE ALTA PRESSÃO F1B7**

- Ideal para ser utilizado como item de camping.

modelo	medidas totais (AxLxP)	peso
F1B7	210 x 406 x 477 mm	2,1 kg
F1B7P (com pedestal)	680 x 406 x 477 mm	2,1 kg

**FOGÃO INDUSTRIAL DE ALTA PRESSÃO F2B10**

- Ideal para ser utilizado como item de camping.

modelo	medidas totais (AxLxP)	peso
F2B10	210 x 409 x 521 mm	2,7 kg
F2B10P (com pedestal)	680 x 409 x 521 mm	2,7 kg

**FOGÃO INDUSTRIAL DE ALTA PRESSÃO F1B3**

- Ideal para ser utilizado como item de camping.

medidas totais (AxLxP)	peso
210 x 300 x 340 mm	1,1 kg

**FOGÃO INDUSTRIAL DE ALTA PRESSÃO F2B6**

- Ideal para ser utilizado como item de camping.

medidas totais (AxLxP)	peso
106 x 450 x 317 mm	2,8 kg

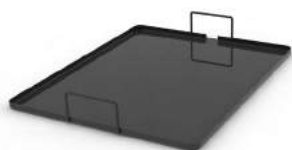
**ACESSÓRIOS OPCIONAIS:****CHAPA COM ALÇAS**

Disponível nas dimensões (LxP):
 320 x 320 mm
 500 x 320 mm
 500 x 400 mm
 740 x 320 mm
 980 x 430 mm

**CHAPA CAMPEIRA**

Dimensões (ø):
 450 mm

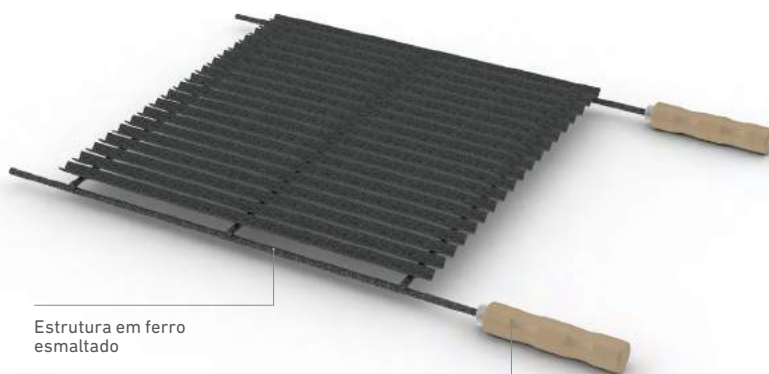
**CHAPA ESMALTADA PGC-004**

Ideal para grelhar carnes, peixes, salsichas, linguças e outros alimentos.

Dimensões área útil (LxP): 400 x 450 mm
 Dimensões totais (LxP): 400 x 777 mm
 Peso líquido: 3,5 kg

CHAPA ESMALTADA PGC-005

Ideal para grelhar carnes, peixes, salsichas, linguças e outros alimentos.

Dimensões área útil (LxP): 500 x 450 mm
 Dimensões totais (LxP): 500 x 777 mm
 Peso líquido: 4 kg





AQUECEDORES DE LOUÇAS E BUFFETS





AQUECEDOR DE LOUÇAS E TALHERES PEL-101 G2

- Desenvolvido para proteger louças e talheres contra qualquer impureza do ambiente;
- Mantém a louça em uma temperatura agradável, permitindo que a comida permaneça quente por mais tempo.

medidas totais (A x L x P)	medidas internas (A x L x P)	peso liq.	consumo médio
533 x 659 x 746 mm	373 x 613 x 693 mm	26,8 kg	1,05 kWh



AQUECEDOR DE LOUÇAS E TALHERES PEL-151 G2

- Desenvolvido para proteger louças e talheres contra qualquer impureza do ambiente;
- Mantém a louça em uma temperatura agradável, permitindo que a comida permaneça quente por mais tempo.

medidas totais (A x L x P)	medidas internas (A x L x P)	peso liq.	consumo médio
533 x 988 x 746 mm	373 x 942 x 693 mm	34 kg	1,05 kWh



**RECHAUD PR-111**

- Fabricado em aço inoxidável de alta resistência;
- Com cubas gastronômicas (GN) removíveis, que podem ser usadas em outros Rechauds ou Buffets.

modelo	n° de cubas	medidas totais (A x L x P)	peso liq.	capacidade
PR-111	2	332 x 577 x 352 mm	4,2 kg	9 litros

BUFFET FRIO GELO X PRBF-30 GN
BUFFET FRIO GELO X PRBF-40 GN
BUFFET FRIO GELO X PRBF-50 GN

modelo	n° de cubas	medidas totais (A x L x P)	peso liq.
PRBF-30 GN	3 - frias	120 x 1120 x 330 mm	9 kg
PRBF-40 GN	4 - frias	120 x 1455 x 330 mm	11,8 kg
PRBF-50 GN	5 - frias	120 x 1790 x 330 mm	14,8 kg



- Acessório complementar: deve ser instalado junto com buffet térmico;
- Cada cuba vem com uma placa de gelo X.

BUFFET TÉRMICO PRB-06 GN
BUFFET TÉRMICO PRB-08 GN
BUFFET TÉRMICO PRB-10 GN

- Estrutura de sustentação tubular;
- Rodízios giratórios que facilitam a locomoção;
- Saída do tanque para drenagem;
- Resistência em aço inox blindado;
- Termostato com controle de temperatura e escala de 10° C a 80° C.



modelo	n° de cubas	medidas totais (A x L x P)	peso liq.	consumo médio
PRB-06 GN	6	1300 x 1130 x 625 mm	29,6 kg	1,2 kWh
PRB-08 GN	8	1300 x 1465 x 625 mm	35,6 kg	1,4 kWh
PRB-10 GN	10	1300 x 1800 x 625 mm	41,8 kg	1,6 kWh



PRB-06 GN



PRB-08 GN

Todos os modelos possuem salvador opcional

ACESSÓRIOS OPCIONAIS:



CUBA INOX GN 1/2 65 MM PRBF

Dimensões externas (AxLxP): 65,6 x 325 x 265 mm
Dimensões internas (AxLxP): 65 x 300 x 240 mm

Disponível para os modelos: PRBF-30 GN, PRBF-40 GN, PRBF-50 GN e REACHAUD PR-111.



CUBA INOX GN 1/2 100 MM PRB

Dimensões externas (AxLxP): 100,6 x 325 x 265 mm
Dimensões internas (AxLxP): 100 x 300 x 240 mm

Disponível para os modelos: PRB-06 GN, PRB-08 GN e PRB-10 GN.



CUBA INOX GN 1/1 100 MM PRB

Dimensões externas (AxLxP): 100,6 x 325 x 530 mm
Dimensões internas (AxLxP): 100 x 300 x 505 mm

Disponível para os modelos: PRB-06 GN, PRB-08 GN e PRB-10 GN.



SALIVADOR



Dimensões (AxLxP):
 PRB-06 GN: 46 x 1137 x 570 mm
 PRB-08 GN: 46 x 1472 x 570 mm
 PRB-10 GN: 46 x 1808 x 570 mm

Disponível para os modelos: PRB-06 GN, PRB-08 GN e PRB-10 GN.



FORNOS TURBOS





FORNO TURBO
PRP-5000 NEW
LIGHT BIVOLT



FORNO TURBO
PRP-5000 NEW
ELETRIC



Saiba mais sobre o PRP-5000 New Light.
Aponte seu leitor de QR Code e assista ao vídeo.

FORNO TURBO PRP-5000 NEW LIGHT BIVOLT



- Iluminação interna resistente a altas temperaturas e choques térmicos;
- Estrutura em aço-carbono com fino acabamento em pintura epóxi;
- Com rodízios que facilitam o deslocamento e controlador com indicação simultânea de tempo e temperatura;
- Isolamento térmico com lã basáltica;
- A turbina liga e desliga automaticamente ao abrir e fechar a porta;
- Tensão: bivolt 127/220 V.

medidas totais (AxLxP)	medidas internas (AxLxP)	peso líq.	consumo médio
1530 x 910 x 1230 mm	470 x 590 x 720 mm	136,5 kg	0,9 kg/h



* Esteiras vendidas separadamente.
Produz em média 125 pães de 50 g por fornada.



FORNO TURBO PRP-5000 NEW ELETRIC

- Com iluminação interna, rodízios que facilitam o deslocamento e controlador com indicação simultânea de tempo e temperatura;
- Estrutura em aço-carbono com fino acabamento em pintura epóxi;
- Isolamento térmico com lã basáltica;
- A turbina liga e desliga automaticamente ao abrir e fechar a porta;
- Equipamento com resistência blindada de 8000 W;
- Tensão: monofásica 220 V ou trifásica 220 ou 380 V.

medidas totais (AxLxP)	medidas internas (AxLxP)	peso líq.	consumo médio
1530 x 910 x 1230 mm	470 x 590 x 720 mm	121 kg	7,3 kWh



* Esteiras vendidas separadamente.
Produz em média 125 pães de 50 g por fornada.



FORNO TURBO PRP-8000 STYLE G2 BIVOLT
FORNO TURBO PRP-10000 STYLE G2 BIVOLT
FORNO TURBO PRP-12000 STYLE G2 BIVOLT



- Iluminação interna resistente a altas temperaturas e choques térmicos;
- Isolamento térmico com lã basáltica e rodízios que facilitam o deslocamento;
- A turbina liga e desliga automaticamente ao abrir e fechar a porta;
- Novo controlador com teclas de programas, receitas, timer, turbina, lâmpada e vapor, além de controlador digital para programar tempo de cozimento, temperatura e vapor;
- Tensão: bivolt 127/220 V.



modelo	nº de esteiras*	capacidade da fornada	medidas totais (A x L x P)	medidas internas (A x L x P)	peso liq.	peso bruto	consumo médio
PRP-8000	8	200 un. de 50 g	1830 x 970 x 1320 mm	930 x 590 x 730 mm	254 kg	308 kg	1,1 kg/h
PRP-10000	10	250 un. de 50 g	1830 x 970 x 1320 mm	1010 x 590 x 730 mm	255 kg	309 kg	1,6 kg/h
PRP-12000	12	300 un. de 50 g	1830 x 970 x 1320 mm	1150 x 590 x 730 mm	277 kg	338 kg	1,8 kg/h

* Esteiras vendidas separadamente.

FORNO TURBO A LENHA PRTL-8000 STYLE BIVOLT
FORNO TURBO A LENHA PRTL-8000 STYLE BIVOLT
FORNO TURBO A LENHA PRTL-10000 STYLE BIVOLT
FORNO TURBO A LENHA PRTL-10000 STYLE BIVOLT



- Com iluminação interna, rodízios que facilitam o deslocamento e controlador digital para programar tempo, temperatura e vapor;
- Isolamento térmico com lã basáltica;
- A turbina liga e desliga automaticamente ao abrir e fechar a porta;
- Tensão: bivolt 127/220 V.



modelo	nº de esteiras*	capacidade da fornada	medidas totais (A x L x P)	medidas internas (A x L x P)	peso liq.	peso bruto	consumo médio
PRTL-8000	8	200 un. de 50 g	1790 x 970 x 1320 mm	930 x 590 x 730 mm	343 kg	399 kg	1,4 kg lenha/h
PRTL-8000	8	200 un. de 50 g	1790 x 970 x 1320 mm	930 x 590 x 730 mm	343 kg	399 kg	1,4 kg lenha/h
PRTL-10000	10	250 un. de 50 g	1790 x 970 x 1320 mm	1010 x 590 x 730 mm	343 kg	399 kg	2 kg lenha/h
PRTL-10000	10	250 un. de 50 g	1790 x 970 x 1320 mm	1010 x 590 x 730 mm	343 kg	399 kg	2 kg lenha/h

* Esteiras vendidas separadamente.



FORNO TURBO PRP-8000 E STYLE
FORNO TURBO PRP-10000 E STYLE



- Com iluminação interna e rodízios que facilitam o deslocamento;
- Isolamento térmico com lã basáltica;
- A turbina liga e desliga automaticamente ao abrir e fechar a porta;
- Novo controlador com teclas de programas, receitas, timer, turbina, lâmpada e vapor, além de controlador digital para programar tempo de cozimento, temperatura e vapor.
- Tensão: monofásica 220 V ou trifásica 220 ou 380 V.



modelo	nº de esteiras*	capacidade da fornada	medidas totais (A x L x P)	medidas internas (A x L x P)	peso liq.	consumo médio
PRP-8000 E	8	200 un. de 50 g	1830 x 970 x 1320 mm	930 x 590 x 730 mm	216 kg	13,5 kWh
PRP-10000 E	10	250 un. de 50 g	1830 x 970 x 1320 mm	1010 x 590 x 730 mm	228 kg	16 kWh

* Esteiras vendidas separadamente.



Saiba mais sobre o Turbo Fast Oven. Aponte seu leitor de QR Code e assista ao vídeo.



Painel digital com teclas individuais para acionamento do motor (turbina) e lâmpada

Controle de tempo e temperatura digital



FORNO TURBO FAST OVEN PRP-004 PLUS

- Com iluminação interna, turbina que distribui o calor uniformemente e timer;
- Isolamento térmico com lã basáltica.

medidas totais (A x L x P)	medidas internas (A x L x P)	peso liq.	litragem	consumo médio
510 x 518 x 665 mm	330 x 460 x 370 mm	21,5 kg	39 litros úteis	1,5 kWh

* Esteiras de 350 x 350 mm cada.



Painel com teclas individuais para acionamento do motor (turbina) e lâmpada



FORNO TURBO FAST OVEN PRP-004 G2

- Com iluminação interna, turbina que distribui o calor uniformemente e timer;
- Isolamento térmico com lã basáltica.

medidas totais (A x L x P)	medidas internas (A x L x P)	peso liq.	litragem	consumo médio
510 x 518 x 665 mm	330 x 460 x 370 mm	22 kg	39 l útil 56 l total	1,5 kWh

* Esteiras de 350 x 350 mm cada.



ACESSÓRIO OPCIONAL:



MESA DESMONTÁVEL MES-004

- Tampo em aço inox;
- Estrutura em aço carbono com pintura epóxi;
- Sapatas plásticas;

- **Dimensões externas (A x L x P):** 906 x 600 x 600 mm
- **Peso líquido:** 16 kg

Disponível para os modelos: PRP-004 G2 e PRP-004 Plus Digital



FORNOS ASSADORES





Espaço mínimo entre assadeiras: 70 mm

Porta traseira móvel

FORNO MULTIUSO GIRATÓRIO PRP-482 G4



- Com rodízios que facilitam o deslocamento, gaveta coletora de gordura e grades giratórias removíveis e reguláveis;
- Tensão: bivolt 127/220 V.

medidas totais (A x L x P)	medidas internas (A x L x P)	peso líq.	consumo médio
1870 x 905 x 985 mm	1430 x 835 x 820 mm	140 kg	0,36/0,28 kg/h (por queimador)



FORNO MULTIUSO GIRATÓRIO PRP-242 G4



- Com rodízios que facilitam o deslocamento, gaveta coletora de gordura e grades giratórias removíveis e reguláveis;
- Tensão: bivolt 127/220 V.

medidas totais (A x L x P)	medidas internas (A x L x P)	peso líq.	consumo médio
1655 x 660 x 805 mm	1215 x 595 x 630 mm	90 kg	0,36/0,28 kg/h (por queimador)



Espaço mínimo entre assadeiras: 70 mm

Porta traseira móvel



FORNO MULTIUSO COMPACTO GIRATÓRIO PRP-124 G



- Com gaveta coletora de gordura e controle progressivo de aquecimento;
- Tensão: bivolt 127/220 V;
- Capacidade para 3 pizzas de ø 45 cm, 12 frangos inteiros de até 2 kg cada ou até 20 kg de carnes diversas.

medidas totais (A x L x P)	peso líq.	consumo médio
810 x 575 x 725 mm	37 kg	0,026 kg/h (por queimador)



* Cada grelha tem ø 48 cm.

**FORNO ASSADOR ROTATIVO INDUSTRIAL PR-6100 DUO**

- Com rodízios que facilitam o deslocamento, gaveta coletora de gordura e bacia interna em aço inox;
- Tensão: bivolt 127/220 V;
- Vem com 10 espetos de frango e 1 de gado (cortesia);
- Capacidade para 10 espetos ou até 100 kg de carne.

medidas totais (AxLxP)	medidas internas (AxLxP)	peso líq.	consumo médio (gás)	consumo médio (elétrico)
1590 x 1145 x 650 mm	1105 x 850 x 530 mm	114 kg	0,35 kg/h (por queimador)	0,38 kWh



* Com 5 frangos de 2 kg cada.



Saiba mais sobre o PR-6100 DUO.

Aponte seu leitor de QR Code e assista ao vídeo.

**FORNO ASSADOR ROTATIVO INDUSTRIAL PR-634**

- Com rodízios que facilitam o deslocamento, gaveta coletora de gordura e bacia interna em aço inox;
- Costas internas esmaltadas;
- Tensão: bivolt 127/220 V;
- Vem com 6 espetos do tipo universal ou garfo.

medidas totais (AxLxP)	medidas internas (AxLxP)	peso líq.	consumo médio
1660 x 1140 x 470 mm	1315 x 850 x 345 mm	73,4 kg	0,20 kg/h (por queimador)



* Com 5 frangos de 2 kg cada.

**FORNO ASSADOR ROTATIVO INDUSTRIAL PR-623**

- Com rodízios que facilitam o deslocamento, gaveta coletora de gordura e bacia interna em aço inox;
- Tensão: bivolt 127/220 V;
- Costas internas esmaltadas;
- Vem com 4 espetos do tipo universal ou garfo.

medidas totais (AxLxP)	medidas internas (AxLxP)	peso líq.	consumo médio
1420 x 1140 x 470 mm	915 x 850 x 345 mm	64,8 kg	0,20 kg/h (por queimador)



* Com 5 frangos de 2 kg cada.

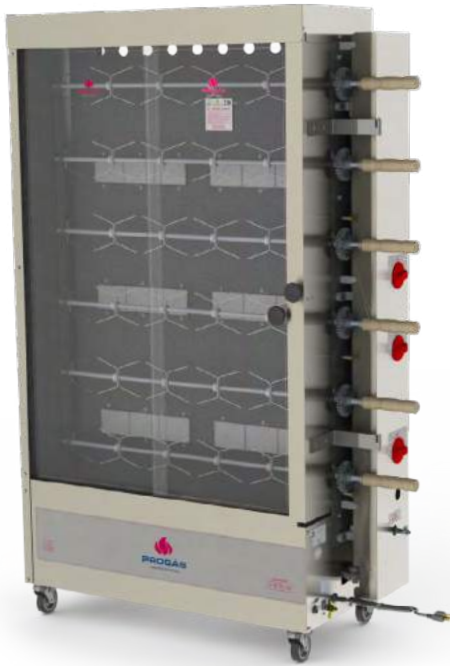

FORNO ASSADOR ROTATIVO INDUSTRIAL PR-631



- Com rodízios que facilitam o deslocamento, gaveta coletora de gordura e bacia interna em aço inox;
- Costas internas esmaltadas;
- Tensão: bivolt 127/220 V;
- Vem com 6 espetos do tipo universal ou garfo.

medidas totais (A x L x P)	medidas internas (A x L x P)	peso liq.	consumo médio
1660 x 1140 x 470 mm	1315 x 850 x 345 mm	85 kg	0,18 kg/h (por queimador)

* Com 5 frangos de 2 kg cada.

ESPETOS E QUEIMADORES:



QUEIMADOR INFRAVERMELHO

Proporciona o aquecimento do forno e, através dos raios infravermelhos, garante a coloração e a melhor apresentação do assado.



QUEIMADOR TUBULAR

Sistema inédito de propagação de calor que proporciona menor consumo de gás.



ESPETO ESPECIAL PARA CARNE

Dimensões (A x L x P): 80 x 37 x 1110 mm
Acompanha o modelo: PR-6100 DUO.



ESPETO GARFO

Dimensões (A x L x P): 80 x 95 x 1115 mm
Acompanha os modelos: PR-623, PR-634, PR-621 e PR-631.



ESPETO UNIVERSAL

Dimensões (A x L x P): 80 x 130 x 1115 mm
Acompanha os modelos: PR-623, PR-634, PR-621 e PR-631.



FORNO ASSADOR ROTATIVO INDUSTRIAL PR-621



- Com rodízios que facilitam o deslocamento, gaveta coletora de gordura e bacia interna em aço inox;
- Tensão: bivolt 127/220 V;
- Costas internas esmaltadas;
- Vem com 4 espetos do tipo universal ou garfo.

medidas totais (A x L x P)	medidas internas (A x L x P)	peso liq.	consumo médio
1420 x 1140 x 470 mm	915 x 850 x 345 mm	72 kg	0,18 kg/h (por queimador)

* Com 5 frangos de 2 kg cada.



Espeto opcional para os dois modelos.

**ASSADOR PR-199
ASSADOR PR-199 E**

modelo	medidas totais (A x L x P)	medidas internas (A x L x P)	peso liq.	consumo médio
PR-199	554 x 252 x 190 mm	486 x 200 x 112 mm	3,6 kg	180 g/h
PR-199 E	554 x 228 x 191 mm	486 x 200 x 64 mm	3,1 kg	1,5 kWh

* Ou 1 espeto vertical de 75 cm.

ACESSÓRIO OPCIONAL:



ESPETO
Dimensões (comprimento): 75 cm

Disponível para: PR-199 e PR-199 E.



FORNO ASSADOR ROTATIVO INDUSTRIAL PRR-520 G2 COLOR STYLE



- Vem com 3 espetos largos para carne e 2 espetos estreitos para coração de galinha;
- Fundo interno galvanizado;
- Bandeja coletora de gordura em aço inox;
- Coletor de gordura na porta.

medidas totais (A x L x P)	medidas internas (A x L x P)	peso liq.	consumo médio	
			gás (por queimador)	elétrico
714 x 587 x 342 mm	601 x 398 x 235 mm	16 kg	0,18 kg/h	0,10 kWh



FORNO ASSADOR ROTATIVO INDUSTRIAL PRR-051 G2 COLOR STYLE (AQUECIMENTO A GÁS)

FORNO ASSADOR ROTATIVO INDUSTRIAL PRR-051 E G2 COLOR STYLE (AQUECIMENTO ELÉTRICO)



- Vem com 3 espetos largos para carne e 2 espetos estreitos para coração de galinha;
- Fundo interno e bandeja coletora de gordura em aço inox;
- Coletor de gordura na porta.

modelo	medidas totais (A x L x P)	medidas internas (A x L x P)	peso liq.	consumo médio	
				gás (por queimador)	elétrico (por queimador)
PRR-051 G2	714 x 587 x 342 mm	601 x 398 x 235 mm	16,5 kg	0,18 kg/h	0,10 kWh
PRR-051 E G2	714 x 587 x 342 mm	601 x 398 x 210 mm	14,8 kg	2,5 kWh	



ACESSÓRIOS OPCIONAIS:
(vendidos separadamente)



ESPETO GRELHA MÚLTIPLO PARA PEIXE
Dimensões (A x L x P):
50 x 100 x 600 mm



CESTO DE AÇO ZINCADO PARA CORAÇÃO PRC-01
Dimensões (Ø x P):
90 x 345 mm
Não acompanha espeto.



ESPETO GRELHA MÚLTIPLO PARA CORAÇÃO
Dimensões (A x L x P):
40 x 100 x 580 mm



GARFO PARA ESPETO PRG-01
Dimensões (A x L x P):
35 x 80 x 590 mm



FORNO ASSADOR ROTATIVO INDUSTRIAL PRR-050 N STYLE



- Vem com 3 espetos largos para carne e 2 espetos estreitos para coração de galinha;
- Com gaveta coletora de gordura;

medidas totais (A x L x P)	medidas internas (A x L x P)	peso liq.	consumo médio	
			gás (por queimador)	elétrico
390 x 750 x 450 mm	240 x 598 x 425 mm	21 kg	0,18 kg/h	0,10 kWh

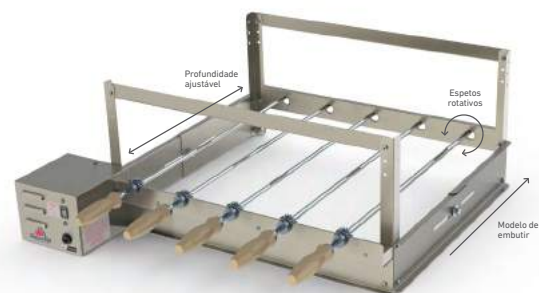

ASSADOR ROTATIVO PRC-05

medidas totais (A x L x P)	peso liq.	consumo médio
315 x 758 x 699 mm	7,5 kg	0,1 kWh





Saiba mais sobre o PRR-040 G STAR. Aponte seu leitor de QR Code e assista ao vídeo.



Forno Assador Rotativo Industrial de Embutir PRR-040 G STAR

- Vem com 4 espetos largos para carne;
- Grade interna com 2 níveis de posição;
- 5 níveis de intensidade de chama;
- Bandeja coletora de gordura;
- Com válvula de segurança para vazamento de gás;
- Sistema exclusivo de 1 motor por espeto.

medidas totais (A x L x P)	medidas internas (A x L x P)	medidas para embutir (A x L x P)	peso líq.	consumo médio	
				gás (por queimador)	elétrico
575 x 710 x 700 mm	290 x 465 x 475 mm	460 x 550 x 650 mm	21,5 kg	0,18 kg/h	0,10 kWh



Grelha Esmaltada

Mesa Lateral

CHURRASQUEIRA AMERICANA PRCA-340

- Assador rotativo;
- Motores individuais;
- Rodas ø 210 mm antiderrapantes;
- Bandeja de carvão e coletor de cinzas em aço inox.

medidas totais (A x L x P)	peso líq.	consumo médio
1071 x 1247 x 712 mm	26 kg	127 V - 0,015 kWh
		220 V - 0,018 kWh





FORNOS REFROTÁRIOS





FORNO REFRAATÁRIO MINI CHEF PRP-400 STYLE G2

- Com porta tipo guilhotina, pés antiderrapantes reguláveis, termômetro analógico e pedra refratária polida;
- Queimador inferior com acendimento por faiscador e queimador superior com acendimento manual.

medidas totais (AxLxP)	medidas internas (AxLxP)	peso líq.	consumo médio	litragem
715 x 600 x 660 mm	210 x 460 x 460 mm	25 kg	0,18 kg/h	40 l

* O peso da pedra refratária já está incluso no peso líquido do produto.



FORNO REFRAATÁRIO MINI CHEF PRPE-400 STYLE G2



- Com porta tipo guilhotina, pés antiderrapantes reguláveis, termostato e pedra refratária polida;
- O equipamento de 127 V vem com resistência de 2500 W; e o de 220 V com resistência de 3300 W.

medidas totais (AxLxP)	medidas internas (AxLxP)	peso líq.	consumo médio	litragem
715 x 600 x 680 mm	190 x 460 x 460 mm	28 kg	2,5 kWh	40 l

* O peso da pedra refratária já está incluso no peso líquido do produto.



ACESSÓRIO OPCIONAL:



CAVALETE MINI CHEF

Dimensões (AxLxP): 800 x 560 x 480 mm
Peso líquido: 20 kg

Disponível para:
Mini Chef PRP-400 Style G2 e Mini Chef PRPE-400 Style G2.

Acompanha pedra refratária



Saiba mais sobre o Little Chef. Aponte seu leitor de QR Code e assista ao vídeo.



FORNO REFRAATÁRIO LITTLE CHEF PRPE-200



- Resistência superior, ideal para gratinar, caramelizar e finalizar pratos;
- Disponível na cor vermelha e inox;
- Perfeito para pizzas, pães rústicos e receitas especiais;
- Resistência do forno: 1800 W;
- Resistência do gratinador: 500 W.

medidas totais (AxLxP)	medidas internas (AxLxP)	peso líq.	consumo médio	capacidade
351 x 374 x 503 mm	190 x 320 x 405 mm	14,5 kg	1,8 kWh	25 l





FORNO REFRACTÁRIO PRP-860 G S/KG

- Com porta tipo guilhotina, sapatas plásticas, gaveta móvel e placas refratárias;
- O equipamento de 127 V vem com resistência de 2500 W; e o de 220 V com resistência de 3300 W.

medidas totais (AxLxP)	medidas internas (AxLxP)	peso liq.	consumo médio	litragem
1480 x 985 x 834 mm	275 x 800 x 600 mm	47 kg	0,7 kg/h	40 l

* O peso da pedra refratária já está incluso no peso líquido do produto.



Saiba mais sobre o PRP-860 G S/KG. Aponte seu leitor de QR Code e assista ao vídeo.



FORNO REFRACTÁRIO FSP-6800 AT

- Com cavalete desmontável, sapatas plásticas, placas refratárias, termômetro para controle de temperatura e faiscador;
- Isolamento térmico em lâ basáltica;
- Câmara interna com suportes para 2 níveis de altura.

medidas totais (AxLxP)	medidas internas (AxLxP)	peso liq.	consumo médio	litragem
1293 x 660 x 733 mm	250 x 505 x 650 mm	49 kg	0,22 kg/h	83 l

* O peso da pedra refratária já está incluso no peso líquido do produto.



PRP-770 G2 S/KG

**FORNO REFRACTÁRIO PRP-750 G2 S/KG
FORNO REFRACTÁRIO PRP-770 G2 S/KG
FORNO REFRACTÁRIO PRP-800 G2 S/KG**

- Com cavalete desmontável, sapatas plásticas, gaveta móvel, placas refratárias, termômetro para controle de temperatura e porta tipo guilhotina;
- Câmara interna com suportes para 2 níveis de altura.

modelo	medidas totais (AxLxP)	medidas internas (AxLxP)	peso liq.	consumo médio	litragem
PRP-750	1405 x 855 x 625 mm	200 x 710 x 430 mm	45 kg	0,35 kg/h	62 l
PRP-770	1480 x 815 x 875 mm	275 x 650 x 680 mm	60,5 kg	0,43 kg/h	125 l
PRP-800	1480 x 615 x 975 mm	275 x 460 x 780 mm	50,5 kg	0,43 kg/h	100 l

* O peso da pedra refratária já está incluso no peso líquido do produto.





PRP-900 G2 S/KG

Forno Refratário PRP-900 G2 S/KG
Forno Refratário PRP-1000 G2 S/KG

- Com cavalete desmontável, sapatas plásticas, gaveta móvel, placas refratárias, termômetro para controle de temperatura e porta tipo guilhotina;
- Câmara interna com suporte para 2 níveis de altura.

modelo	medidas totais (AxLxP)	medidas internas (AxLxP)	peso liq.	consumo médio	litragem
PRP-900	1480 x 1100 x 1105 mm	275 x 910 x 910 mm	84,5 kg	0,7 kg/h	230 l
PRP-1000	1480 x 1100 x 925 mm	275 x 910 x 730 mm	81,5 kg	0,58 kg/h	182 l

* O peso da pedra refratária já está incluso no peso líquido do produto.



Forno Refratário PRP-900 DP G2 S/KG

- Com cavalete desmontável, sapatas plásticas, gaveta móvel, placas refratárias, termômetro para controle de temperatura e porta tipo guilhotina;
- Câmara interna com suportes para 2 níveis de altura.

medidas totais (AxLxP) cada forno	medidas internas (AxLxP)	peso liq.	consumo médio	litragem
980 x 1105 x 1100 mm	275 x 910 x 910 mm	164,5 kg	1,52 kg/h	individual 230 l juntos 460 l

* O peso da pedra refratária já está incluso no peso líquido do produto.



Estrutura e laterais em aço-carbono com fino acabamento em pintura epóxi

Forno Refratário PRP-1500 G2 KG

- Com cavalete desmontável, sapatas plásticas, gaveta móvel, placas refratárias, termômetro para controle de temperatura e porta tipo guilhotina;
- Câmara interna com suporte para 2 níveis de altura.

medidas totais (AxLxP)	medidas internas (AxLxP)	peso liq.	consumo médio	litragem
1600 x 1420 x 1640 mm	300 x 1180 x 1440 mm	209,5 kg	2,1 kg/h	495 l

* O peso da pedra refratária já está incluso no peso líquido do produto.





Controle automático de temperatura por termostato



FORNO REFRAATÓRIO PRPE-770 G2

- Com cavalete desmontável, sapatas plásticas, placas refratárias, termômetro para controle de temperatura e porta tipo guilhotina;
- Câmara interna com suporte para 2 níveis de altura.

medidas totais (AxLxP)	medidas internas (AxLxP)	peso liq.	consumo médio	litragem
1510 x 900 x 865 mm	245 x 655 x 680 mm	65 kg	4 kWh	117 l

* O peso da pedra refratária já está incluso no peso líquido do produto.



Controle automático de temperatura por termostato



FORNO REFRAATÓRIO PRPE-900 G2

- Com cavalete desmontável, sapatas plásticas, placas refratárias, termômetro para controle de temperatura e porta tipo guilhotina;
- Câmara interna com suporte para 2 níveis de altura.

medidas totais (AxLxP)	medidas internas (AxLxP)	peso liq.	consumo médio 127 V	consumo médio 220 V	litragem
1510 x 1115 x 1125 mm	245 x 910 x 905 mm	88 kg	4 kWh	6 kWh	210 l

* O peso da pedra refratária já está incluso no peso líquido do produto.



Com queimadores infravermelhos na parte superior - ideais para gratinar

PRPI-900 G2 KG



Estrutura e laterais em aço-carbono com fino acabamento em pintura epóxi

Comando de vapor: 127 ou 220 V

FORNO REFRAATÓRIO PRPI-800 G2 KG
FORNO REFRAATÓRIO PRPI-900 G2 KG

- Com cavalete desmontável, sapatas plásticas, gaveta móvel, placas refratárias, termômetro para controle de temperatura e porta tipo guilhotina;
- Câmara interna com suporte para 2 níveis de altura.

modelo	medidas totais (AxLxP)	medidas internas (AxLxP)	peso liq.	consumo médio	litragem
PRPI-800	1480 x 615 x 975 mm	275 x 460 x 780 mm	51,5 kg	0,2 kg/h (por queimador)	100 l
PRPI-900	1480 x 1100 x 1105 mm	275 x 910 x 910 mm	87,5 kg	0,2 kg/h (por queimador)	230 l

* O peso da pedra refratária já está incluso no peso líquido do produto.



FORNO REFRAATÓRIO PRP-1500 AT G2

- Com cavalete desmontável, gaveta móvel, placas refratárias, termômetro para controle de temperatura e porta tipo guilhotina;
- Câmara interna com suporte para 2 níveis de altura.

medidas totais (AxLxP)	medidas internas (AxLxP)	peso liq.	consumo médio	litragem
1600 x 1460 x 1640 mm	300 x 1180 x 1440 mm	228 kg	2,1 kg/h	495 l

* O peso da pedra refratária já está incluso no peso líquido do produto.







CÂMARAS DE CRESCIMENTO





CÂMARAS DE CRESCIMENTO PRCL-200 G2 E PRCL-400 G2



- Sistema integrado de aquecimento elétrico e refrigeração.



modelo	medidas totais (AxLxP)	peso líq.	consumo médio	capacidade
PRCL-200 G2	2052 x 744 x 1043 mm	129 kg	1,0 kWh	20 esteiras
PRCL-400 G2	2093 x 744 x 1769 mm	222 kg	1,4 kWh	40 esteiras

* Para esteiras de 580 x 700 mm, 400 x 600 mm e 450 x 650 mm.

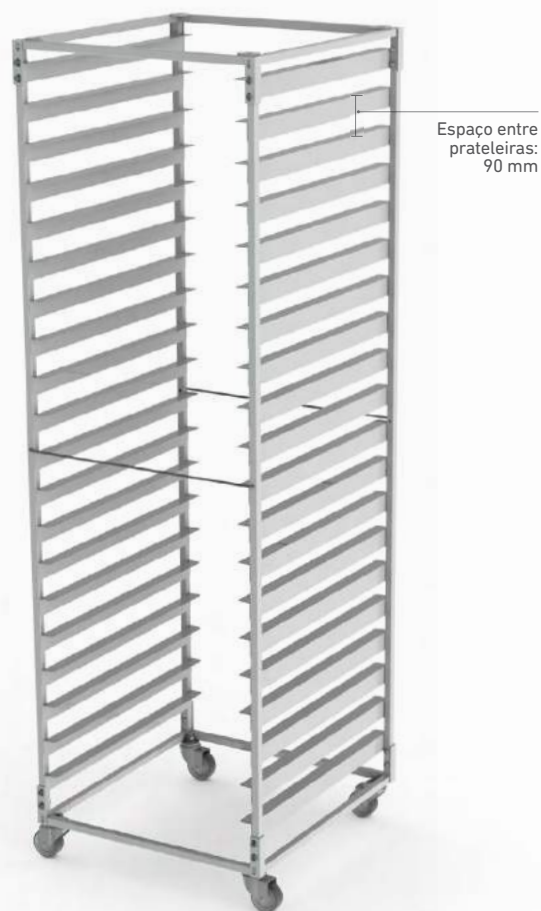

CÂMARA DE CRESCIMENTO PCA-200 N STYLE

- Rodízios que facilitam o deslocamento;
- Pode ser entregue montado ou desmontado;
- 4 tipos de esteiras opcionais: retas, flandres, onduladas ou 5 tiras.

medidas totais (AxLxP)	capacidade de armazenagem	peso líq.
1986 x 640 x 810 mm	500 un. de 50 g	48 Kg



*580 x 700 mm com 25 pães de 50 g cada.

CÂMARA DE CRESCIMENTO PCE-200

- Rodízios que facilitam o deslocamento;
- 4 tipos de esteiras opcionais: retas, flandres, onduladas ou 5 tiras.

medidas totais (AxLxP)	capacidade de armazenagem	peso líq.
2015 x 635 x 690 mm	500 un. de 50 g	25 kg



*580 x 700 mm com 25 pães de 50 g cada.

ACESSÓRIOS OPCIONAIS:



ESTEIRA RETA

Dimensões (AxLxP):
25 x 580 x 670 mm
Peso líquido: 1,38 kg

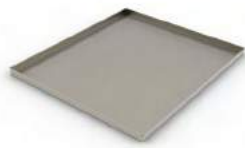

ESTEIRA FLANDRES

Dimensões (AxLxP):
25 x 580 x 670 mm
Peso líquido: 1,68 kg



ESTEIRA ONDULADA

Dimensões (AxLxP):
25 x 580 x 670 mm
Peso líquido: 1,6 kg



ESTEIRA 5 TIRAS

Dimensões (AxLxP):
25 x 580 x 700 mm
Peso líquido: 1,3 kg





ESTANTES E GÔNDOLAS

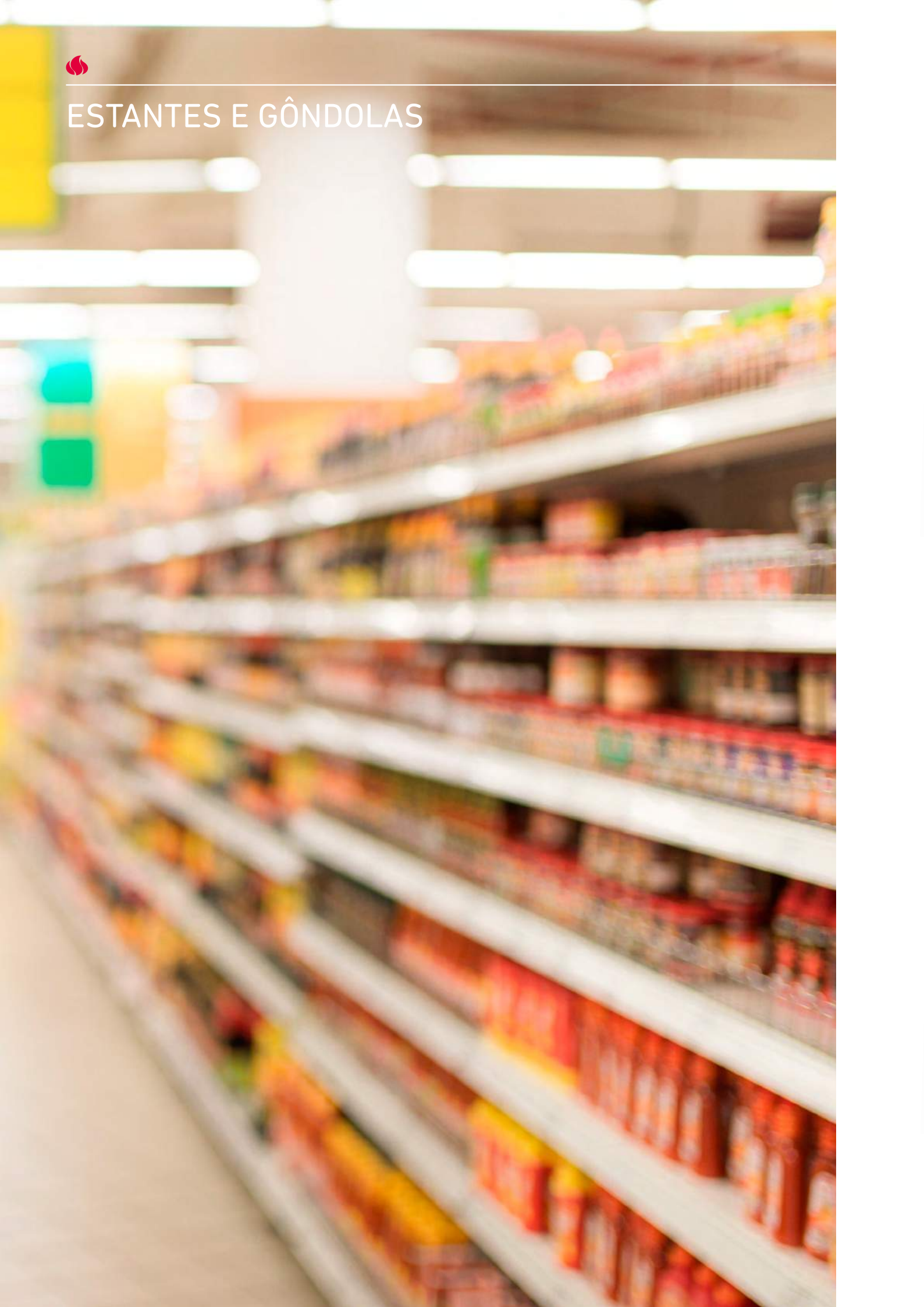



ESTANTE REGULÁVEL PREST-004

- Altura mínima entre as prateleiras: 250 mm;
- Altura útil entre as 4 prateleiras com distribuição uniforme: 500 mm.



modelo	medidas totais (AxLxP)	peso liq.
PREST-004	1820 x 1110 x 500 mm	34 kg
• Coluna	1800 x 47 x 47 mm	2,5 kg
• Prateleira	40 x 1090 x 480 mm	6,5 kg



ESTANTE REGULÁVEL PREST-006

- Altura mínima entre as prateleiras: 180 mm;
- Altura útil entre as 6 prateleiras com distribuição uniforme: 360 mm.



modelo	medidas totais (AxLxP)	peso liq.
PREST-006	2000 x 920 x 320 mm	16 kg
• Coluna	2000 x 40 x 40 mm	1 kg
• Prateleira	30 x 900 x 300 mm	1,8 kg



Gôndola de Encosto



Gôndola Podium de Ponta

GÔNDOLAS

- Sistema totalmente encaixável e personalizável: módulos podem ser combinados com os acessórios;
- Perfis porta-etiquetas opcionais em PVC com sistema de encaixe: disponíveis nas cores azul ou vermelho (outras cores sob consulta);
- Gôndolas com base de 40 cm: prateleiras de 30 cm;
- Gôndolas com base de 50 cm: prateleiras de 40 cm.



* Distribuídos uniformemente.

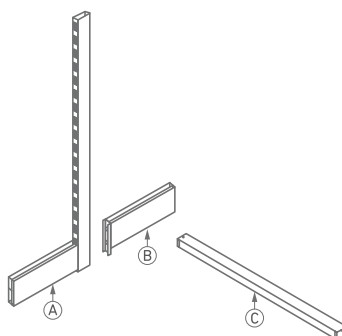

- a) **Coluna Padrão:** disponível para todos os modelos de gôndolas de encosto e de centro, conforme as respectivas alturas;
- b) **Pé Coluna Padrão:** para as colunas de centro;
- c) **Fechamento Superior:** para gôndolas de ponta. Uso opcional em gôndolas de encosto e de centro.



MEDIDAS:

PRATELEIRAS

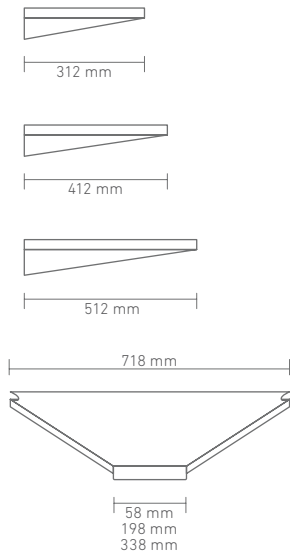

GÔNDOLA MONTADA

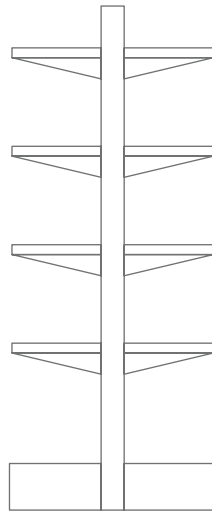

COLONAS DE REGULAGEM



BASE CEREAL

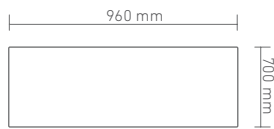

FECHAMENTO SUPERIOR

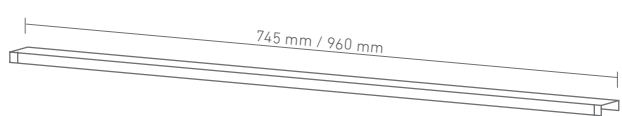

ACESSÓRIOS:

• Com acabamento em pintura epóxi.



CESTO DE CENTRO



CESTO DE PONTA



SEPARADOR DE PRATELEIRA



APARADOR DE PONTA



APARADOR DE CENTRO



SUPORTE PRATELEIRA GRAU



BASE CEREAL REFORÇADA



SUPORTE GANCHO CENTRO



SEPARADOR DE CESTOS



GANCHO BÁSICO



GANCHO SIMPLES



GANCHO DUPLO

ÍNDICE DE PRODUTOS BRAESI

Equipamentos para Padarias e Casas de Massas	86
Equipamentos para Açougues	96
Máquina de Algodão-Doce e Pipoqueira	100
Despolpadeiras	102
Processadores Multiuso	104
Prensas	108
Cilindros Manuais	109



BRAESI

equipamentos gastronômicos







EQUIPAMENTOS PARA PADARIAS E CASAS DE MASSAS





AMASSADEIRA ESPIRAL AES-05

- Ideal para misturas de pão francês, pão caseiro e massas em geral;
- Estrutura em aço com pintura epóxi e cuba em aço inox;
- Grade de segurança que desliga o equipamento ao ser levantada;
- Disponível em 3 cores: branco, vermelho e preto;
- Equipamento monofásico com 10 velocidades.

medidas totais (A x L x P)	capac. farinha	capac. massa pronta	peso líq.	consumo médio
470 x 339 x 689 mm	3 kg	5 kg	38 kg	0,8 kWh



AMASSADEIRA ESPIRAL AES-15/1

- Ideal para misturas de pão francês, pão caseiro e massas em geral;
- Caretagem em polímero termoformado de alta resistência e cuba em aço inox;
- Batedor em ferro fundido com acabamento estanhado;
- Equipamento trifásico ou monofásico com 2 velocidades.

medidas totais (A x L x P)	capac. farinha	peso líq.	motor	consumo médio
789 x 435 x 885 mm	9 kg	96 kg	monof. 220 V - 1.5 CV	0,95 kWh



AMASSADEIRA ESPIRAL AES-25/1 N STYLE

- Ideal para misturas de pão francês, pão caseiro e massas em geral;
- Caretagem em polímero termoformado de alta resistência e cuba em aço inox;
- Grade de segurança que desliga o equipamento ao ser levantada;
- Equipamento trifásico ou monofásico com 2 velocidades.

medidas totais (A x L x P)	capac. farinha	peso líq.	motor	consumo médio
985 x 520 x 1060 mm	15 kg	164 kg	trif. 220 ou 380 V - 1,6/2,5 CV monof. 220 V - 2 CV	2,98 kWh 2,6 kWh

**AMASSADEIRA ESPIRAL AES-40/1 N STYLE**

- Ideal para misturas de pão francês, pão caseiro e massas em geral;
- Carenagem em polímero termoforado de alta resistência e cuba em aço inox;
- Grade de segurança que desliga o equipamento ao ser levantada;
- Equipamento trifásico ou monofásico com 2 velocidades.

medidas totais (A x L x P)	capac. farinha	peso líq.	motor	consumo médio
985 x 600 x 1200 mm	25 kg	182 kg	trif. 220 ou 380 V - 2,5/4 CV monof. 220 V - 3 CV	2,98 kWh 2,6 kWh

**AMASSADEIRA SEMIRRÁPIDA ALI-05**

- Ideal para misturas de pães, cucas, massas, biscoitos e outros;
- Carenagem em polímero termoforado de alta resistência e cuba em aço inox;
- Com sistema basculante e pás fixas.

medidas totais (A x L x P)	capac. farinha	peso líq.	motor	consumo médio
525 x 503 x 357 mm	3 kg	25 kg	monof. bivolt 127/220 V - 1/2 CV	0,49 kWh

**ACESSÓRIO OPCIONAL:****KIT MOEDOR DE CARNE**

- Com pino central, navalha, chapa e bocal 9 em ferro fundido com banho de estanho;
- Bandeja em aço inox.

Dimensões (A x L x P): 370 x 220 x 320 mm
Disponível para o modelo: AELI-520 e AELI-310.

**AMASSADEIRA ESPIRAL AES-60/1 N STYLE**

- Ideal para misturas de pão francês, pão caseiro e massas em geral;
- Carenagem em polímero termoforado de alta resistência e cuba em aço inox;
- Grade de segurança que desliga o equipamento ao ser levantada.

medidas totais (A x L x P)	capac. farinha	peso líq.	motor	consumo médio
1082 x 600 x 1200 mm	40 kg	205 kg	trif. 220 ou 380 V - 2,5/4 CV	2,98 kWh



Saiba mais sobre a AELI-520. Aponte seu leitor de QR Code e assista ao vídeo.

**AMASSADEIRA SEMIRRÁPIDA CONJUGADA AELI-520**

- Carenagem e tampa em polímero termoforado de alta resistência, cuba e bandeja em aço inox e bocal em bronze;
- Com sistema basculante semirrápido e socador para massas;
- Extrusora com moldes para 7 tipos de massas e 4 tipos de biscoitos.

medidas totais (A x L x P)	capac. farinha	peso líq.	motor	consumo médio
612 x 694 x 357 mm	mín. 3 kg	42 kg	monof. bivolt 127/220 V - 3/4 CV	0,49 kWh





Saiba mais sobre a AELI-310. Aponte seu leitor de QR Code e assista ao vídeo.

Equipado com tampa em termoplástico transparente com dispenser para inserir ingredientes sem abrir a tampa



Fechamento em termoformado de alta resistência

Base em MDF, resistente à umidade



Acompanham:
5 moldes para massas
2 moldes para biscoito



Socador



Kit extrusor para massas e biscoitos / moedor para carnes

Funil para ensacar língua



28 cm



Kit laminador



AMASSADEIRA SEMIRRÁPIDA AELI-310

- Ideal para misturas de pães, cucas, massas, biscoitos e outros;
- Com bacia em aço inox, mais leve e durável;
- Com kit laminador;
- Com kit extrusor para massas e biscoitos / moedor para carnes.

medidas totais s/ acessórios (AxLxP)	capac. farinha	peso liq.	motor	consumo médio
283 x 585 x 262 mm	2 kg	22,3 kg	monof. 127 ou 220 V - 1/3 CV	0,49 kWh



AMASSADEIRA SEMIRRÁPIDA ALI-03

- Ideal para misturas de pães, cucas, massas, biscoitos e outros;
- Com bacia em aço inox, mais leve e durável;
- Com dispenser para inserir ingredientes sem abrir a tampa.

medidas totais (AxLxP)	capac. farinha	peso liq.	motor	consumo médio
283 x 615 x 278 mm	2 kg	12,4 kg	monof. 127 ou 220 V - 1/3 CV	0,26 kWh



Saiba mais sobre a ALI-15/1. Aponte seu leitor de QR Code e assista ao vídeo.



AMASSADEIRA SEMIRRÁPIDA ALI-15/1

- Ideal para preparo de massas pesadas para pães rústicos, pizzas e panetones.

medidas totais (AxLxP)	peso liq.	consumo médio	capac. farinha	motor
770 x 572 x 471 mm	54,5 kg	0,49 kWh	10 kg	monof. bivolt 127/220 V - 1/2 CV



AMASSADEIRA SEMIRRÁPIDA ALI-25/1 G3

- Amassadeira mais compacta e atualizada;
- Com sistemas de descarga e balsa inovadores.

medidas totais (AxLxP)	capac. farinha	peso liq.	motor	consumo médio
813 x 700 x 471 mm	15 kg	73 kg	trif. 220 ou 380 V - 1 CV monof. bivolt 127/220 V - 3/4 CV	0,88 kWh 0,49 kWh



**AMASSADEIRA RÁPIDA AR-15/1 G3**

- Ideal para misturas de pão francês, pão caseiro e massas em geral;
- Carenagem e tampa em polímero termoformado de alta resistência e cuba em aço inox escovado;
- Tampa em aço inox escovado.

medidas totais (A x L x P)	capac.	peso liq.	tensão	motor	consumo médio
553 x 434 x 681 mm	15 kg	61,2 kg	127 ou 220 V	monof. bivolt 127/220 V - 2 CV	1,8 kWh

**AMASSADEIRA RÁPIDA AR-25/1 G3**

- Ideal para misturas de pão francês, pão caseiro e massas em geral;
- Carenagem e tampa em polímero termoformado de alta resistência e cuba em aço inox escovado;
- Tampa em aço inox escovado.

medidas totais (A x L x P)	capac.	peso liq.	tensão	motor	consumo médio
671 x 557 x 784 mm	18 kg	100 kg	220 V	monof. bivolt 127/220 V - 3 CV	2,6 kWh

**AMASSADEIRA RÁPIDA AR-25/1 T G3**

- Ideal para misturas de pão francês, pão caseiro e massas em geral;
- Carenagem e tampa em polímero termoformado de alta resistência e cuba em aço inox escovado;
- Tampa em aço inox escovado.

medidas totais (A x L x P)	capac.	peso liq.	tensão	motor	consumo médio
671 x 557 x 784 mm	25 kg	100 kg	220 ou 380 V	monof. bivolt 127/220 V - 4 CV	2,6 kWh

**AMASSADEIRA RÁPIDA AR-50 N STYLE**

- Ideal para misturas de pão francês, pão caseiro e massas em geral;
- Carenagem e tampa em polímero termoformado de alta resistência e cuba em aço inox escovado.

medidas totais (A x L x P)	capac. farinha	peso liq.	motor	consumo médio
458 x 371 x 595 mm	3 kg	40 kg	monof. bivolt 127/220 V - 1 CV	0,9 kWh





Parte superior basculante: desliga automaticamente o equipamento ao ser levantada

Troca rápida de batedor



POTÊNCIA
800 W

Saiba mais sobre a BPEL-05 Premium G2. Aponte seu leitor de QR Code e assista ao vídeo.



Carenagem em polímero termoformado de alta resistência

10 níveis de velocidade

Mais potente do mercado: 800 W

Grade de proteção cromada



Vem com batedor espiral, batedor raquete e batedor globo.



BATEDEIRA ELETRÔNICA PLANETÁRIA COMPACTA BPEL-05 PREMIUM G2

- Mais compacta e dinâmica;
- Alto desempenho e qualidade;
- Moderno sistema eletrônico de velocidade.



medidas totais (AxLxP)	peso líq.	consumo médio	capacidade
408 x 292 x 457 mm	17,6 kg	0,64 kWh	5 l



BATEDEIRA ELETRÔNICA PLANETÁRIA BPEL-12/1 G3

- Engenhosa, mais compacta;
- Design exclusivo;
- Sistema eletrônico de troca de velocidades continuamente variável;
- Tampa em polímero termoformado de alta resistência, cuba em aço inox e grade cromada.

medidas totais (AxLxP)	peso líq.	consumo médio	capacidade
623 x 380 x 571 mm	30 kg	0,64 kWh	12 l



Vem com batedor espiral, batedor raquete e batedor globo.



Saiba mais sobre a BPEL-18/1 G2. Aponte seu leitor de QR Code e assista ao vídeo.



BATEDEIRA ELETRÔNICA PLANETÁRIA BPEL-18/1 G2

- Tampa em polímero termoformado de alta resistência, cuba em aço inox e grade cromada;
- Sistema de troca de velocidade progressiva com polia variadora;
- Sistema de engrenagens helicoidais;
- Grade de segurança que desliga o equipamento ao ser levantada.

medidas totais (AxLxP)	peso líq.	consumo médio
699 x 386 x 590 mm	43 kg	0,7 kWh



Vem com batedor espiral, batedor raquete e batedor globo.



Saiba mais sobre a BLB-300.
Aponte seu leitor de QR Code e assista ao vídeo.

Vidro 300 mm
incolor temperado



BAILARINA DE CONFEITAR BLB-300

- Eixo com duplo rolamento;
- Base em polipropileno disponível nas cores vermelho, azul e rosa.

medidas totais (Altura)	peso líq.
144 mm	1,4 kg



CILINDRO LAMINADOR ELÉTRICO DE MASSAS CB-38 COMPACTO

- Estrutura em aço com pintura epóxi;
- Eixos dos rolos apoiados em rolamentos;
- Cilindros revestidos em material teflon, com raspadores em nylon.

medidas totais (AxLxP)	peso líq.	motor	consumo médio
353 x 598 x 217 mm	11,5 kg	monof. bivolt 127/220 V - 1/3 CV	0,26 kWh



ACESSÓRIO OPCIONAL:

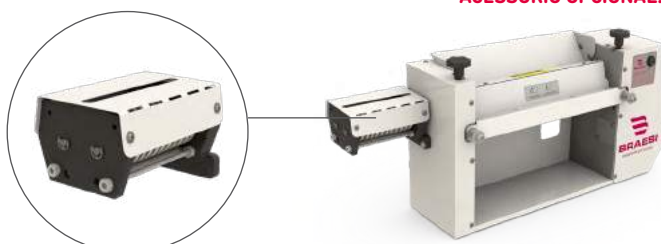

CORTADOR DE TALHARIM BCM-245

• Dimensões (AxLxP): 101 x 168 x 108 mm

Disponível para o modelo: CB-38.



Carenagem em polímero termoformado de alta resistência



CILINDRO LAMINADOR CB-30 STYLE

- Eixos apoiados em rolamentos com rolo superior (cilindro: 300 x 50 mm);
- Cilindros laminadores revestidos em cromo duro, com raspadores plásticos.

medidas totais (A x L x P)	peso líq.	motor	consumo médio
535 x 496 x 545 mm	28,5 kg	monof. bivolt 127/220 V - 1/2 CV	0,55 kWh



Acompanha pedestal

Bocal de 40 cm

Laterais em polímero termoformado de alta resistência



CILINDRO LAMINADOR CBPI-40/1 G2

- Grade de segurança zincada;
- Chapa de segurança dos rolos em inox.

medidas totais (A x L x P)	motor	peso líq.	consumo médio	capacidade
1540 x 680 x 940 mm	monof. 3/4 cv	82,3 kg	0,60 - 0,55 kWh	5 kg



Bandeja em aço inox escovado



CILINDRO LAMINADOR CBI-500/1 N STYLE

- Eixos apoiados em rolamentos (cilindro: 500 x 125 mm).

medidas totais (A x L x P)	peso líq.	motor	consumo médio
1660 x 840 x 1440 mm	193 kg	2 monof. ou trif. 220 ou 380 V - 1,5 CV	1,8 kWh



**MODELADORA DE PÃES MB-35/1 G2**

- Carenagem em polímero termoformado de alta resistência e bandeja de retorno com pintura epóxi;
- Grade de segurança que desliga o equipamento ao ser levantada;
- Com rodízios para facilitar o deslocamento e alavanca para regular o tamanho.

medidas totais (A x L x P)	peso líq.	motor	consumo médio
1156 X 593 X 843 mm	64,4 kg	monof. bivolt 127/220 V - 1/4 CV	0,6 kWh



* Capacidade mínima: 20 g de massa.

**MODELADORA DE PÃES MBMJ-22/1 STYLE G2**

- Carenagem em polímero termoformado de alta resistência;
- Grade de segurança que desliga o equipamento ao ser levantada;
- Com alavanca para regular o tamanho.

medidas totais (A x L x P)	peso líq.	motor	consumo médio
408 X 459 X 653 mm	40,1 kg	monof. bivolt 127/220 V - 1/4 CV	0,6 kWh



* Capacidade mínima: 20 g de massa.

**DIVISORA DE PÃES DVB-30 N**

- Bandeja e lâminas de corte em aço inox.

medidas totais (A x L x P)	peso líq.	peso bruto
950 x 425 x 550 mm	45 kg	50 kg

**ACESSÓRIO OPCIONAL:****MESA PARA DIVISORA MES-30 DESMONTÁVEL**

- Estrutura em aço-carbono;
- Acabamento em pintura epóxi.

Disponível para o modelo: DVB-30 N.

Dimensões (A x L x P):
850 x 540 x 600 mm

Peso Líquido: 14 kg



MESA PANIFICADORA M-160 G2
MESA PANIFICADORA M-180 G2
MESA PANIFICADORA M-190 G2

modelo	medidas totais (AxLxP)	peso líquido
M-160 G2	870 x 1600 x 600 mm	29 kg
M-180 G2	870 x 1900 x 800 mm	46,5 kg
M-190 G2	870 x 1900 x 900 mm	51 kg



FATIADORA DE PÃO FB-12/1

- Mesas em aço inox e lâminas em aço-carbono;
- Com dispositivo para embalar pão e bandeja para resíduos;
- Fatia pães de até 16 cm de altura.

medidas totais (AxLxP)	peso liq.	motor	consumo médio
1260 x 650 x 900 mm	73 kg	monof. bivolt 127/220 V - 1/3 CV	0,5 kWh



MESA PANIFICADORA MBR-10
MESA PANIFICADORA MBR-015 G2
MESA PANIFICADORA MBR-018 G2

modelo	medidas totais (AxLxP)	peso líquido
MBR-10	870 x 930 x 600 mm	17 kg
MBR-015 G2	870 x 1600 x 600 mm	22,5 kg
MBR-018 G2	870 x 1900 x 800 mm	35,5 kg



MOINHO PARA PÃO MP-02

- Ideal para fazer farinha de rosca.

medidas totais (AxLxP)	peso liq.	motor	consumo médio
800 x 210 x 340 mm	16 kg	monof. bivolt 127/220 V - 1 CV	0,7 kWh

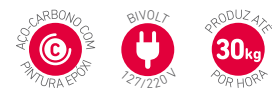



EQUIPAMENTOS PARA AÇOUGUES





Com socador



Com funil para ensacar linguiça

MOEDOR DE CARNE BMC-05 G2

- Carenagem em polímero termoformado de alta resistência;
- Caixa de engrenagem imersa em óleo;
- Bandeja, socador e funil em polipropileno (PP);
- Transmissão por caixa de redução.

medidas totais (A x L x P)	peso liq.	peso bruto	motor	consumo médio
290 x 220 x 385 mm	11,3 kg	11,8 kg	monof. bivolt 127/220 V - 1/4 CV	0,4 kWh

**MOEDOR DE CARNE BMC-10/1 G2**

- Estrutura em aço inox escovado;
- Caixa de engrenagem imersa em óleo;
- Socador em polipropileno (PP);
- Transmissão por caixa de redução.

medidas totais (A x L x P)	peso liq.	peso bruto	motor	consumo médio
480 x 290 x 565 mm	28 kg	30 kg	monof. bivolt 127/220 V - 1/2 CV	0,6 kWh

**MOEDOR DE CARNE BMC-22/1 G2**

- Estrutura em aço inox escovado;
- Caixa de engrenagem imersa em óleo;
- Socador em polipropileno (PP);
- Transmissão por caixa de redução.

medidas totais (A x L x P)	peso liq.	peso bruto	motor	consumo médio
500 x 305 x 725 mm	43 kg	44 kg	monof. bivolt 127/220 V - 1,25 CV	1,3 kWh



**SERRA-FITA BSIM-178 PLUS SEMI-INOX**

- Sistema prático de limpeza dos componentes;
- Volante em ferro fundido com \varnothing 220 mm e lâmina de corte em aço temperado com 5/8" x 1780 mm;
- Com pés antiderrapantes.

medidas totais (AxLxP)	peso líq.	motor	consumo médio
868 x 495 x 438 mm	32 kg	monof. bivolt 127/220V - 1/2 CV	0,18 kWh

**SERRA-FITA BSFM-1780/1**

- Sistema prático de limpeza dos componentes;
- Volante em ferro fundido com \varnothing 220 mm e lâmina de corte em aço temperado com 5/8" x 1780 mm.

medidas totais (AxLxP)	peso líq.	motor	consumo médio
890 x 555 x 639 mm	47,4 kg	monof. bivolt 127/220 V - 1/2 CV	0,18 kWh

**ACESSÓRIO OPCIONAL:****KIT MOEDOR DE CARNE**

- Com pino central, navalha, chapa e bocal 9 em ferro fundido com banho de estanho;
- Bandeja em aço inox.

Dimensões (AxLxP):
370 x 220 x 320 mm

Disponível para o modelo: BSFM-1780/1.

**MESA BMES-1780 / 178**

- Estrutura em aço-carbono;
- Acabamento em pintura epóxi branca.

Dimensões (AxLxP):
705 x 524 x 454 mm

Peso: 9 kg

Disponível para os modelos: BSIM-178
BSFM-1780/1.



Mesa móvel em aço inox com 690 x 810 mm



SERRA-FITA BSFP-2820/1

- Sistema prático de limpeza dos componentes;
- Volante em ferro fundido com \varnothing 310 mm e lâmina de corte em aço temperado com 5/8" x 2820 mm.

medidas totais (AxLxP)	peso liq.	motor	consumo médio
1755 x 810 x 730 mm	105 kg	monof. bivolt 127/220 V - 1 CV	0,20 kWh



Mesa em aço inox



Mesa móvel em aço inox com 690 x 810 mm

SERRA-FITA BSFPI-282 SEMI-INOX

- Sistema prático de limpeza dos componentes;
- Volante em ferro fundido com \varnothing 310 mm e lâmina de corte em aço temperado com 5/8" x 2820 mm.

medidas totais (AxLxP)	peso liq.	motor	consumo médio
1755 x 810 x 730 mm	105 kg	monof. bivolt 127/220 V - 1 CV	0,20 kWh



CORTADOR DE FRIOS CFBA-30/1 G2



- Com regulagem para fatiar frios e rebolos para afiar o disco cortador;
- Base em chapa de aço;
- Disco de corte com \varnothing 300 mm.

medidas totais (AxLxP)	peso liq.	motor	consumo médio
857 x 357 x 643 mm	53,5 kg	monof. bivolt 127/220 V - 1/3 CV	0,2 kWh





MÁQUINA DE ALGODÃO-DOCE E PIPOQUEIRA





Carenagem em polímero termoformado de alta resistência



MÁQUINA DE ALGODÃO-DOCE ADB-02 G2

- Sistema exclusivo com resistência blindada;
- Controle de temperatura por potenciômetro;
- Painel com interruptor geral/motor e potenciômetro.

medidas totais (A x L x P)	peso líq.	motor	consumo médio
367 x 490 x 490 mm	9,1 kg	monof. 220 V - 1/4 CV	1,25 kWh



Com lâmpada interna

Com perfis de alumínio

Saiba mais sobre a BMP-150 I. Aponte seu leitor de QR Code e assista ao vídeo.



PIPOQUEIRA BMP-150 I

- Parte superior em polímero termoformado de alta resistência, panela basculante em aço cromado com tampa de inox e parte interna em alumínio;
- Conjunto misturador estanhado e gaveta de resíduos;
- Resistência inferior com potência de 200 W blindada e resistência da panela com potência de 1000 W blindada;
- Controle automático da temperatura.

medidas totais (A x L x P)	peso líq.	consumo médio
680 x 560 x 360 mm	20 kg	1 kWh



DESPOLPADEIRAS





IDEAL PARA:

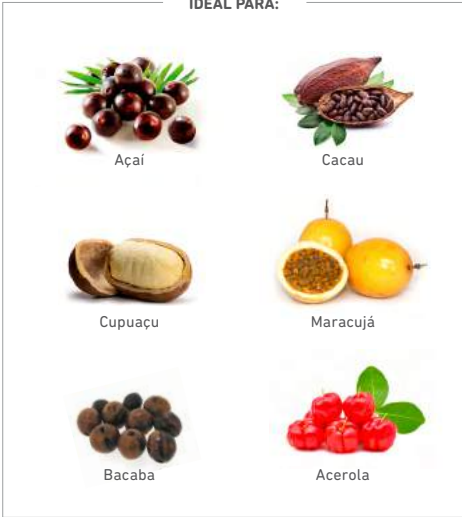

Vem com 3 peneiras em aço inox com furos de:



DESPOLPADEIRA DES-10
DESPOLPADEIRA DES-20

- Carenagem em polímero termoformado de alta resistência e cuba em aço inox.

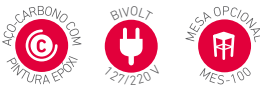

modelo	medidas totais (A x L x P)	peso liq.	motor	consumo médio	capacidade
DES-10	1100 x 390 x 580 mm	32,5 kg	monof. bivolt 127/220 V - 1/3 CV	0,5 kWh	10 l
DES-20	1100 x 390 x 650 mm	35 kg	monof. bivolt 127/220 V - 1/2 CV	0,7 kWh	20 l

IDEAL PARA:



Vem com 2 peneiras em aço inox com furos de:



ø 1,2 mm:
para frutas com sementes pequenas e polpa líquida.

ø 1,5 mm:
para frutas com sementes maiores e polpa mais consistente, como pêssigo, goiaba e maçã.



Bocal em alumínio

DESPOLPADEIRA DES-60/1 G2



medidas totais (A x L x P)	peso líquido	motor	consumo médio	capacidade
686 x 320 x 847 mm	25,4 kg	monof. 127/220 V - 1/2 CV	0,35 kWh	65 kg/h



PROCESSADORES MULTIUSO





DESCASCADOR DE LEGUMES BDL-10

- Tampa plástica em ABS ou polímero termoformado de alta resistência com abertura para visualização e entrada dos legumes;
- Com pés antiderrapantes, saída de resíduos e porta para descarga dos legumes.



medidas totais (A x L x P)	peso liq.	motor	consumo médio
690 x 442 x 586 mm	28 kg	monof. bivolt 127/220 V - 1/3 CV	0,49 kWh



FATIADOR DE TOMATES E COGUMELOS FLB-180

- Com 12 lâminas em aço inox 304.



medidas totais (A x L x P)	peso líquido
217 x 266 x 349 mm	5 kg



Vem com 3 discos de
ø 150 mm em aço inox:

**RASPADOR DE COCO BRC-50 G2**

- Bacia em plástico;
- Carenagem em polímero termoformado de alta resistência.

medidas totais (AxLxP)	motor	consumo médio	peso
368 x 260 x 319 mm	monof. bivolt 127/220 V - 1/4 CV	0,2 kWh	7,2 kg

**FURADOR DE COCO FC-01**

- Perfurador em aço inox.

medidas totais (AxLxP)	peso líq.
553 x 220 x 420 mm	3,06 kg

**RALADOR DE QUEIJO E COCO RQ-01**

- Bocal removível em alumínio.

medidas totais (AxLxP)	peso líquido	motor	consumo médio
395 x 280 x 490 mm	20 kg	monof. 127 ou 220 V - 1/3 CV	0,26 kWh

**ACESSÓRIOS OPCIONAIS:****MESA MES-100 MULTIUSO**

- Estrutura em aço-carbono;
- Acabamento em pintura epóxi branca.

Dimensões (AxLxP): 666 x 551 x 351 mm
Peso líquido: 6,5 kg

Disponível para:
DES-10, DES-20, DES-60, RQ-01, BRC-050 e FC-01.





PRENSAS

PRENSAS



Tábua de prensagem: ø 300 mm

Cavalete com acabamento em pintura epóxi

PRENSA DE TORRESMO BPTI-300

medidas totais (AxLxP)	peso líq.
780 x 430 x 325 mm	10 kg

PRENSA DE TORRESMO BPTL-300

medidas totais (AxLxP)	peso líq.
780 x 430 x 325 mm	10 kg

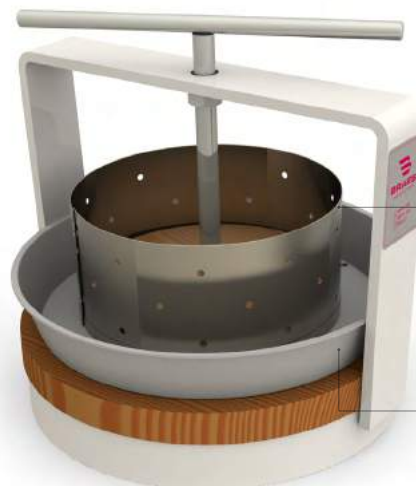

Vem com 3 formas em aço inox

Com bacia para remoção do soro



Forma P Retangular: para queijos de 1 kg



Forma M Retangular: para queijos de 1,5 kg



Forma G Redonda: ø 200 mm

PRENSA DE QUEIJO BPQ-03

medidas totais (AxLxP)	peso líquido
440 x 330 x 330 mm	6,3 kg





CILINDROS MANUAIS



CILINDRO MANUAL BCMF-300 FIRENZE

- Cilindros laminadores de 2" x 300 mm revestidos em cromo duro;
- Engrenagens em nylon, laterais em alumínio e lâmina de apoio em aço-carbono com pintura epóxi.

medidas totais (AxLxP)	peso líquido
385 x 245 x 145 mm	2,4 kg



CILINDRO MANUAL BCMV-300 VENEZA

- Cilindros laminadores de 2" x 300 mm revestidos em cromo duro;
- Engrenagens em nylon, laterais em polipropileno e lâmina de apoio em aço-carbono com pintura epóxi.

medidas totais (AxLxP)	peso líquido
311 x 487 x 157 mm	2,6 kg



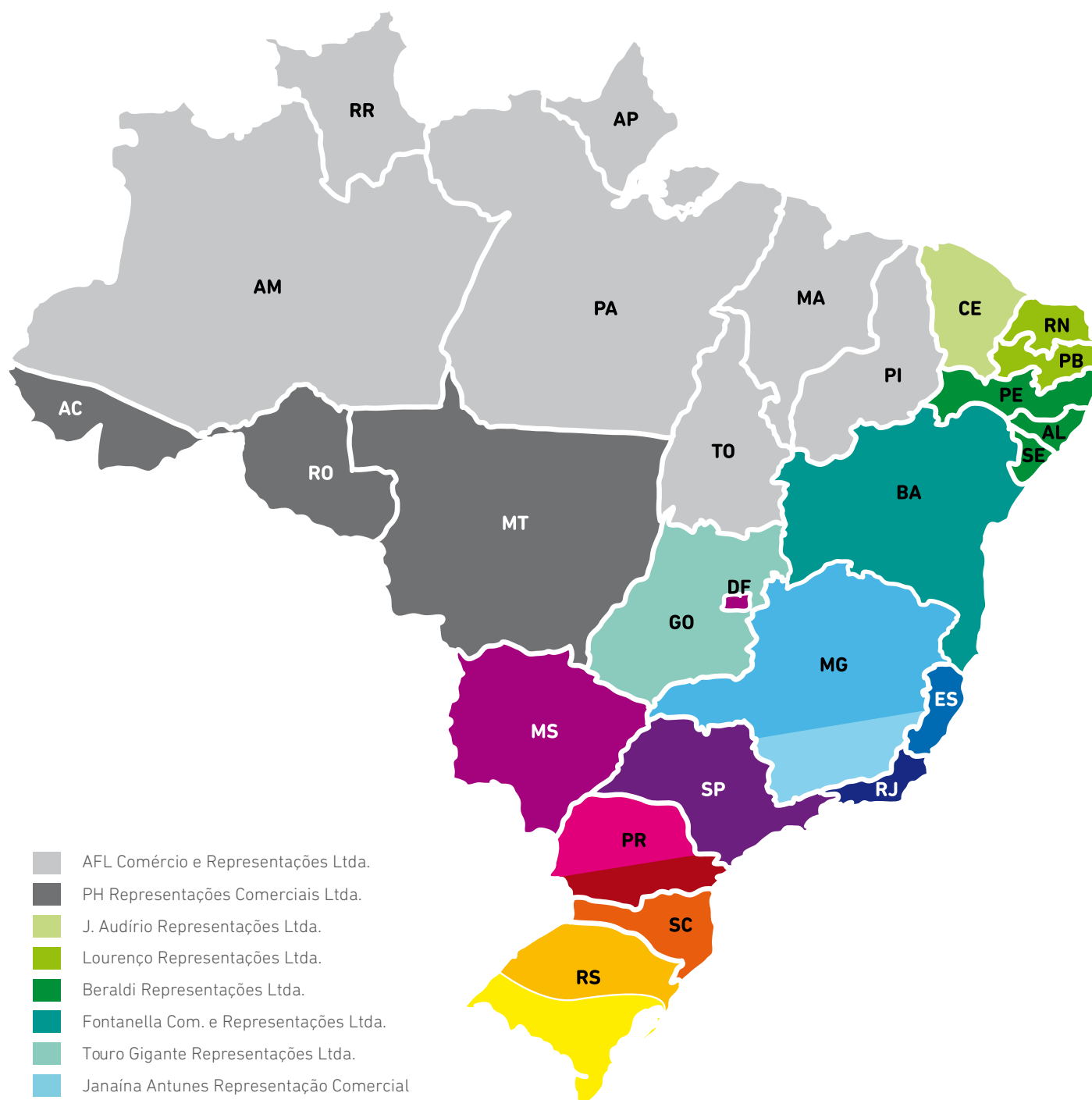

- AFL Comércio e Representações Ltda.
- PH Representações Comerciais Ltda.
- J. Audírio Representações Ltda.
- Lourenço Representações Ltda.
- Beraldi Representações Ltda.
- Fontanella Com. e Representações Ltda.
- Touro Gigante Representações Ltda.
- Janáina Antunes Representação Comercial
- Domingos e Bernardes Representações Ltda.
- Dornelles Representações (AA Dornelles)
- Gastardelli Santos Representações Comerciais Ltda.
- Plena Representações Ltda.
- RD Representação Comercial Ltda.
- Marques Representações Comerciais
- Comercial Marka Ltda.
- Reprecom Comércio e Representações Ltda.
- Claugem Comércio e Representações Ltda.
- Brillhance Comércio e Representações Ltda. (Institucional)
- Gubert Representações

Comércio Exterior:

Reibraz Representações Ltda.

Distribuidores Autorizados:

Santiago, Chile: Progás Braesi Chile Imp. y Repres. Ltda.

Montevideu, Uruguai: Pimetal S.A

AFL COMÉRCIO E REPRESENTAÇÕES LTDA.

AMAPÁ | AMAZONAS | MARANHÃO | PARÁ | PIAUÍ | RORAIMA | TOCANTINS

Goiânia - GO:

62 3579.1072 | 3579.2075 | 99972.1720
aflrep@gmail.com

Manaus - AM:

92 98829.5075
topmak@gmail.com

BERALDI REPRESENTAÇÕES LTDA.

ALAGOAS | PERNAMBUCO | SERGIPE

Recife - PE:

81 3241.3110 | 3129.4494 | 98686.1110
jberaldi@uol.com.br
beraldi.assistencia@hotmail.com

BRILHANCE COMÉRCIO E REPRESENTAÇÕES LTDA. (INSTITUCIONAL).

51 3340.2315 | 98407.4555 (Vivo)
98486.7784 (Oi) | 98567.6170 (Oi)
brilhanc.voy@terra.com.br

CLAUGEM COMÉRCIO E REPRESENTAÇÕES LTDA.

CENTRO, NORTE E NORDESTE DO RIO GRANDE DO SUL

54 3222.6440 | 54 99125.6151
claugem@terra.com.br

COMERCIAL MARKA LTDA.

SUL DO PARANÁ

41 3282.2313 | 99971.1125 | 99917.6682
comercialmarka@yahoo.com.br

DOMINGOS E BERNARDES REPRESENTAÇÕES LTDA.

NORTE / MINAS GERAIS

Belo Horizonte:

31 98780.1450

Uberlândia:

34 3223.1648
progasminas2@gmail.com

DORNELLES REPRESENTAÇÕES (AA DORNELLES)

ESPIRITO SANTO

54 99185.6328
alexandreaadornelles@hotmail.com

FONTANELLA COMÉRCIO E REPRESENTAÇÕES LTDA.

BAHIA

54 3537.6121 | 71 99601.7171
atendimento@fontanella.net.br

GASTARDELLI SANTOS REPRES. COM. LTDA. ME.

RIO DE JANEIRO

24 2245.5254 | 2221.2472 | 98831.0010 | 98818.0020
vendas@ggsrepresentacoes.com.br

GUBERT REPRESENTAÇÕES.

PÓRTO ALEGRE E SUL DO RIO GRANDE DO SUL

54 99901.6080
gubertrepresentacoes@gmail.com

JANAÍNA ANTUNES REPRESENTAÇÃO COMERCIAL

SUL E ZONA DA MATA | MINAS GERAIS

54 99913.0991 | 54 99646.2903
jana.antunesrepresentacoes@gmail.com

J. AUDÍRIO REPRESENTAÇÕES

CEARÁ

85 3055.3361 | 3296.3361 | 85 99807.0100
99807.0111 | 99807.0203 jaudiriorep@gmail.com

LOURENÇO REPRESENTAÇÕES LTDA.

RIO GRANDE DO NORTE E PARAÍBA

85 3253.4393 | 3252.1441 | 98728.0421
comercial@lourencorepresentacoes.com.br
pedidos@lourencorepresentacoes.com.br

MARQUES REPRESENTAÇÕES COMERCIAIS

NORTE DO PARANÁ

Maringá:

44 99972.5602 | 99161.3423 | 3246.1375
marquesltda@yahoo.com.br

PH REPRESENTAÇÕES COMERCIAIS EIRELI

MATO GROSSO | RONDÔNIA | ACRE

62 3095.7314 | 62 99623.1715 | 65 99997.9696
phmariadocarmo@gmail.com

PLENA REPRESENTAÇÕES LTDA.

MATO GROSSO DO SUL E DISTRITO FEDERAL

62 3248.8438 | 99972.2010
tomassl@uol.com.br

RD REPRESENTAÇÃO COMERCIAL LTDA.

SÃO PAULO

19 3255.5661 | 99112.3856
rdrepvendas@terra.com.br

REPRECOM REPRESENTAÇÕES LTDA.

SANTA CATARINA

47 3348.1360 | 99976.9613 | 99605.0323
reprecom@reprecom.com.br
www.reprecom.com.br

TOURO GIGANTE REPRESENTAÇÕES LTDA. ME

GOIÁS

62 3259.1112 | 99968.1402
tgigante@terra.com.br
neudatqs@terra.com.br

COMÉRCIO EXTERIOR:

REIBRAZ REPRESENTAÇÕES LTDA.

+55 51 3268.6621 | +55 51 3026.5599
+55 51 99234.7530 | +55 51 99234.6554
reibraz@varani.com.br

DISTRIBUIDORES AUTORIZADOS:

PROGÁS/BRAESI CHILE IMP. Y REPRES. LTDA.

SANTIAGO - CHILE

562 2778.4876 | 569 9719.0311
alberttable@hotmail.com
www.progasbraesi.cl

PIMETAL S.A.

MONTEVIDÉU - URUGUAI

598 2204.2999 | 598 2203.6891
maquinaria.pimetal@hotmail.com